

## Operating instructions

# 9499 040 82111

valid from: 8437

# Contents

---

Foreword .....	3
Safety Precautions .....	3
Handling Precautions .....	4
How to Use This Manual .....	4
Checking the Contents of the Package .....	4
Removing the Packing Materials .....	6
<b>Function Introduction/Names of Parts .....</b>	<b>8</b>
Function Introduction .....	8
Names of Parts .....	9
Display and Key Panel .....	10
<b>Installing/Wiring the Recorder .....</b>	<b>11</b>
Installation Location .....	11
Installation Procedure .....	11
⚠ Input Signal Wiring .....	13
⚠ Optional Terminal Wiring .....	15
⚠ Power Supply Wiring .....	17
<b>Common Operations and Menu Structure .....</b>	<b>18</b>
Execution Modes .....	18
Operation Sequence .....	18
Key Operation .....	19
Menu Structure of Setting Mode .....	22
Menu Structure of Basic Setting Mode .....	23
<b>Preparing to Record .....</b>	<b>24</b>
Loading or Replacing the Chart Paper .....	24
Installing/Replacing the Plotter Pen (Pen Model) .....	27
Installing/Replacing the Ribbon Cassette (Dot Model) .....	27
Checking or Setting the Date/Time .....	29
<b>Setting the Input Range and Alarm on Measurement Channels .....</b>	<b>30</b>
Setting the Input Range .....	30
Setting the Alarm .....	34
<b>Recording/Displaying Data .....</b>	<b>36</b>
Starting the Recording .....	36
Stopping the Recording .....	36
Feeding the Chart Paper .....	36
Changing the Chart Speed .....	37
Viewing the Recorded Results .....	37
Description of the Printout Contents .....	38
Switching the Display Screen .....	40
Changing the Displayed Information .....	41
FUNC Key Operations in Operation Mode .....	42
Printing Measured Values (Manual Printout) .....	42
Printing the Recorder Settings .....	43
Clearing the Alarm Printout Buffer .....	44
Printing a Message .....	44
Releasing the Alarm Output (Alarm ACK Operation) .....	45
Activating/Releasing the Key Lock .....	45
<b>Setup Items and Default Values .....</b>	<b>46</b>
Setup Items in Setting Mode and Their Default Values .....	46
Setup Items in Basic Setting Mode and Their Default Values .....	47
<b>Recommended Replacement Periods for Worn Parts .....</b>	<b>51</b>

## Foreword

Thank you for purchasing the industrial chart recorder. This manual describes concisely the operating procedures of the recorder. To ensure correct use, please read this manual thoroughly before beginning operation. The following manuals, in addition to this one, are provided as manuals for the recorder. Please read all of them.

### Electronic Manuals Provided on the Accompanying CD-ROM

Manual Title	Manual No.
<b>Industrial Chart Recorder User's Manual</b> Explains all the functions and procedures of the recorder excluding the communication functions.	9499-040-82111
<b>Industrial Chart Recorder Communication Interface User's Manual</b> Explains the communication functions using Ethernet interface and the RS-422A/485 communication interface.	9499-040-82211
<b>Industrial Chart Recorder Operation Guide</b> This is the electronic version of the paper manual.	9499-040-82011

### Opening the Electronic Manuals

The PDF files of the manuals are provided on the accompanying CD-ROM.

Insert the CD-ROM in the PC's CD-ROM drive. Double click ENGLISH directory > manual name directory > manual number to open the manual in the My Computer > RECORDER\_MANUALS directory.

## Notes

- The contents of this manual are subject to change without prior notice as a result of continuing improvements to the instrument's performance and functions.
- Every effort has been made in the preparation of this manual to ensure the accuracy of its contents. However, should you have any questions or find any errors, please contact your nearest dealer.
- Copying or reproducing all or any part of the contents of this manual without the permission of us is strictly prohibited.
- The TCP/IP software of this product and the document concerning the TCP/IP software have been developed/created by us based on the BSD Networking Software, Release 1 that has been licensed from the University of California.

## Trademarks

- Microsoft, MS-DOS, Windows, Windows NT, and Windows XP are either registered trademarks or trademarks of Microsoft Corporation in the United States and/or other countries.
- Adobe, Acrobat, and PostScript are trademarks of Adobe Systems Incorporated.
- For purposes of this manual, the TM and ® symbols do not accompany their respective trademark names or registered trademark names.
- Company and product names that appear in this manual are trademarks or registered trademarks of their respective holders.

## Revisions

1st Edition February 2006

## Safety Precautions

The general safety precautions described here must be observed during all phases of operation.

### • Safety Standards and EMC Standards

This recorder conforms to IEC safety class I (provided with terminal for protective grounding), Installation Category II, Measurement category II (CAT II), and EN61326-1 (EMC standard), class A (use in a commercial, industrial, or business environment). This recorder is designed for indoor use.

### • About This Manual

- This manual should be read by the end user.
- Read this manual thoroughly and have a clear understanding of the product before operation.
- This manual explains the functions of the product. We do not guarantee that the product will suit a particular purpose of the user.
- Under absolutely no circumstances may the contents of this manual be transcribed or copied, in part or in whole, without permission.
- The contents of this manual are subject to change without prior notice.
- Every effort has been made in the preparation of this manual to ensure the accuracy of its contents. However, should you have any questions or find any errors or omissions, please contact your nearest dealer.

### • Precautions Related to the Protection, Safety, and Alteration of the Product

- The following safety symbols are used on the product and in this manual.



"Handle with care." To avoid injury and damage to the instrument, the operator must refer to the explanation in the manual.



Protective ground terminal



AC



"High temperature." To avoid injury caused by hot surface, do not touch locations where this symbol appears.

- For the protection and safe use of the product and the system controlled by it, be sure to follow the instructions and precautions on safety that are stated in this manual whenever you handle the product. Take special note that if you handle the product in a manner that violate these instructions, the protection functionality of the product may be damaged or impaired. In such cases, we do not guarantee the quality, performance, function, and safety of the product.
- When installing protection and/or safety circuits such as lightning protection devices and equipment for the product and control system or designing or installing separate protection and/or safety circuits for fool-proof design and fail-safe design of the processes and lines that use the product and the control system, the user should implement these using additional devices and equipment.
- If you are replacing parts or consumable items of the product, make sure to use parts specified by us.
- This product is not designed or manufactured to be used in critical applications that directly affect or threaten human lives. Such applications include nuclear power equipment, devices using radioactivity, railway facilities, aviation equipment, air navigation facilities, aviation facilities, and medical equipment. If so used, it is the user's responsibility to include in the system additional equipment and devices that ensure personnel safety.
- Do not modify this product.

---

## **WARNING**

### • **Power Supply**

Ensure that the source voltage matches the voltage of the power supply before turning ON the power.

### • **Protective Grounding**

Make sure to connect the protective grounding to prevent electric shock before turning ON the power.

### • **Necessity of Protective Grounding**

Never cut off the internal or external protective earth wire or disconnect the wiring of the protective earth terminal. Doing so invalidates the protective functions of the instrument and poses a potential shock hazard.

### • **Defect of Protective Grounding**

Do not operate the instrument if the protective earth or fuse might be defective. Make sure to check them before operation.

### • **Do Not Operate in an Explosive Atmosphere**

Do not operate the instrument in the presence of flammable liquids or vapors. Operation in such environments constitutes a safety hazard.

### • **Do Not Remove Covers**

The cover should be removed by our qualified personnel only. Opening the cover is dangerous, because some areas inside the instrument have high voltages.

### • **External Connection**

Connect the protective grounding before connecting to the item under measurement or to an external control unit.

### • **Damage to the Protective Structure**

Operating the recorder in a manner not described in this manual may damage its protective structure.

---

### • **Exemption from Responsibility**

- We make no warranties regarding the product except those stated in the WARRANTY that is provided separately.
- We assume no liability to any party for any loss or damage, direct or indirect, caused by the user or any unpredictable defect of the product.

## **Handling Precautions**

- Use care when cleaning the recorder, especially any plastic parts. When cleaning, wipe using a dry soft cloth. Do not use chemicals such as benzene or thinner, since these may cause discoloring and deformation.
- Keep electrically charged objects away from the signal terminals. This may damage the recorder.
- Do not apply volatile chemicals to the door glass, display, panel keys, etc. Do not allow rubber and vinyl products to remain in contact with the recorder for long periods of time. This may damage the recorder.
- When not in use, make sure to turn OFF the power switch.
- If there are any symptoms of trouble such as strange odors or smoke coming from the recorder, immediately turn OFF the power switch and the power supply source. Then, contact your nearest dealer.

## **How to Use This Manual**

This manual covers information regarding the recorders with English as the display/recording language (suffix code "2"). The following markings are used in this manual.



*Improper handling or use can lead to injury to the user or damage to the instrument.* This symbol appears on the instrument to indicate that the user must refer to the user's manual for special instructions. The same symbol appears in the corresponding place in the user's manual to identify those instructions. In the manual, the symbol is used in conjunction with the word "WARNING" or "CAUTION."

### **WARNING**

Calls attention to actions or conditions that could cause serious or fatal injury to the user, and precautions that can be taken to prevent such occurrences.

### **CAUTION**

Calls attention to actions or conditions that could cause light injury to the user or damage to the instrument or user's data, and precautions that can be taken to prevent such occurrences.

### *Note*

Calls attention to information that is important for proper operation of the instrument.

## **Checking the Contents of the Package**

Unpack the box and check the contents before operating the instrument. If some of the contents are not correct or missing or if there is physical damage, contact the dealer from which you purchased them.

### **Industrial Chart Recorder**

A name plate is affixed to the case. Check that the model name and suffix code given on the name plate match those on your order.

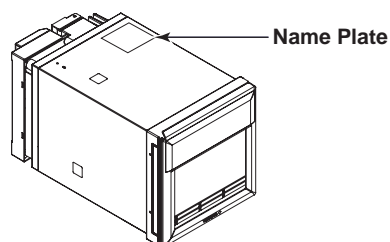

### **NO. (Instrument Number)**

When contacting the dealer from which you purchased the instrument, please give them the instrument number.

### MODEL and SUFFIX Code

Item	Description	Conventions used in this manual
1 pen recorder	Number of inputs for measurement: 1	-
2 pen recorder	Number of inputs for measurement: 2	-
3 pen recorder	Number of inputs for measurement: 3	-
4 pen recorder	Number of inputs for measurement: 4	-
6 dot recorder	Number of inputs for measurement: 6	-
Language	English/German/French	-
Options	Alarm output relay 2 points <sup>1</sup>	/A1
	Alarm output relay 4 points <sup>1</sup>	/A2
	Alarm output relay 6 points <sup>1, 2</sup>	/A3
	RS-422A/485 interface <sup>3</sup>	/C3
	Ethernet (10BASE-T) interface <sup>3</sup>	/C7
	Fail/Chart end detection and output <sup>2</sup>	/F1
	Clamped input terminal <sup>4</sup>	/H2
	Non-glare door glass	/H3
	Mathematical function	/M1
	Cu10, Cu25 RTD input	/N1
	3 legs isolated RTD <sup>4, 5</sup>	/N2
Expansion inputs <sup>6</sup>	/N3	
Remote control 5 points	/R1	

- 1 /A1, /A2, and /A3 cannot be specified simultaneously.
- 2 /A3 and /F1 cannot be specified simultaneously.
- 3 /C3 and /C7 cannot be specified simultaneously.
- 4 /H2 and /N2 cannot be specified simultaneously.
- 5 Valid only on the model 436106.
- 6 14 types of input including Pt50 RTD, PR40-20, and Platinel TC

### Optional Accessories (Sold Separately)

The optional accessories below are available for purchase separately. If you make an order, make sure that all contents are present and undamaged.

For information about ordering accessories, contact the dealer from which you purchased the recorder.

Item	Quantity	Note
Z-fold chart paper	1	10 pcs.
Ribbon cassette	1	
Disposable felt pen	Red	3 pcs.
	Green	3 pcs.
	Blue	3 pcs.
	Violet	3 pcs.
Plotter pen	1	3 pcs.
Mounting bracket	2	
Shunt resistor for the screw terminal (standard)	1	250 Ω ± 0.1%
	1	100 Ω ± 0.1%
	1	10 Ω ± 0.1%
Shunt resistor for the clamped input terminal (/H2)	1	250 Ω ± 0.1%
	1	100 Ω ± 0.1%
	1	10 Ω ± 0.1%

### Standard Accessories

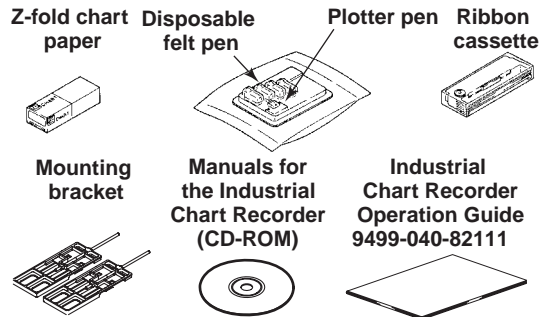

Item	1-Pen	2-Pen	3-Pen	4-Pen	Dot	
Z-fold chart paper	1	1	1	1	1	
Ribbon cassette	-	-	-	-	1	
Disposable felt pen	Red	1	1	1	-	
	Green	-	1	1	-	
	Blue	-	-	1	1	-
	Violet	-	-	-	1	-
Plotter pen	1	1	1	1	-	
Mounting bracket	2	2	2	2	2	
Manuals for the Industrial Chart Recorder (CD-ROM)	1	1	1	1	1	
Industrial Chart Recorder Operation Guide 9499-040-82111	1	1	1	1	1	

---

## Removing the Packing Materials

Open the door, put your finger on the tab at the lower left of the display and key panel section, and open the display and key panel section.

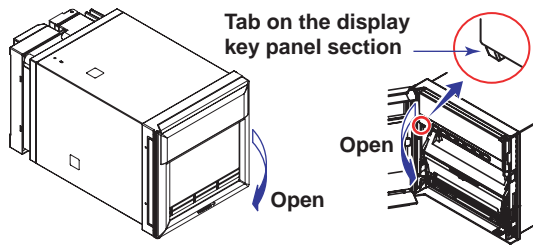

Remove all packing materials.

- Pen Model

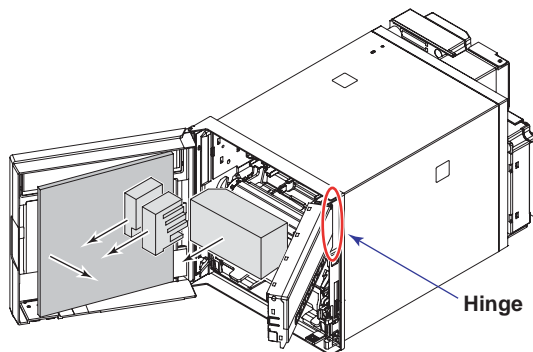

- Dot Model

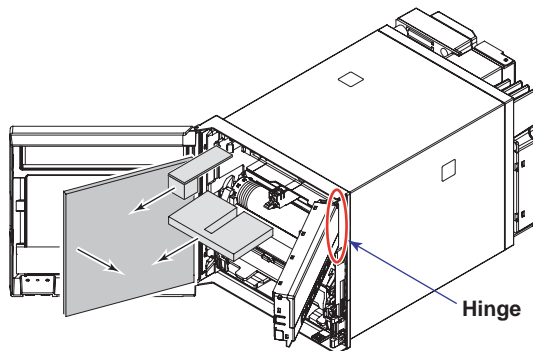

---

### **CAUTION**

To protect the hinges, do not apply vertical force on the display and key panel section.

---

---

# Memo

# Function Introduction/Names of Parts

## Function Introduction

The Recorder (hereafter referred to as the recorder) can be used to assign DC voltage, 1-5V, thermocouple, RTD, and contact or voltage ON/OFF signal to channels for measurement. The measured results are recorded with pens or dots on a chart paper that is fed at a constant speed. The pen model can record up to 4 channels; the dot model can record up to 6 channels.

Recorder

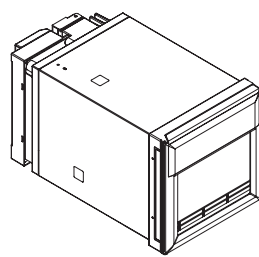

Recording example (dot model)



### Alarms

For each channel, various alarms such as high limit alarm and low limit alarm can be assigned to monitor the measured values. Alarm output relays can be used to output contact signals when alarms occur (/A1, /A2, and /A3 options).

### Recording

The measured results are recorded with pens or dots on a chart paper (trend recording). The chart speed can be selected from 5 to 12000 mm/h on the pen model and 1 to 1500 mm/h on the dot model.

In addition to trend recording, various types of information can be printed on the chart paper such as numeric measured values, alarm occurrence/release, and predefined messages.

Also, the recorder settings can be printed.

### Internal Light

A light is provided for easier viewing of the recording area of the chart paper.

### Display

Measured values can be displayed numerically or using bar graphs on the large display. Also, alarm status and chart speed can be displayed.

### Communication Functions

Using the Ethernet communication interface (/C7 option) or the RS-422A/485 communication interface (/C3 option), the measured values on the recorder can be output to a computer or a computer can be used to control the recorder.

For details on communication functions, see the *Communication Interface User's Manual* (9499-040-82211) on the CD-ROM.

### Other Main Functions

The computation function (/M1 option) can be used to perform various computations from four arithmetic operations to statistical calculations on 8 and 12 computation channels on the pen model and dot model, respectively. The computed results can be recorded.

The remote control function (/R1 option) can be used to control the recording start/stop and other operations of the recorder by applying contact signals to the dedicated terminals.

The FAIL/chart end detection and output function (/F1 option) can be used to output contact signals when errors are detected on the recorder or when the chart paper runs out.



**Names of Parts  
Front**

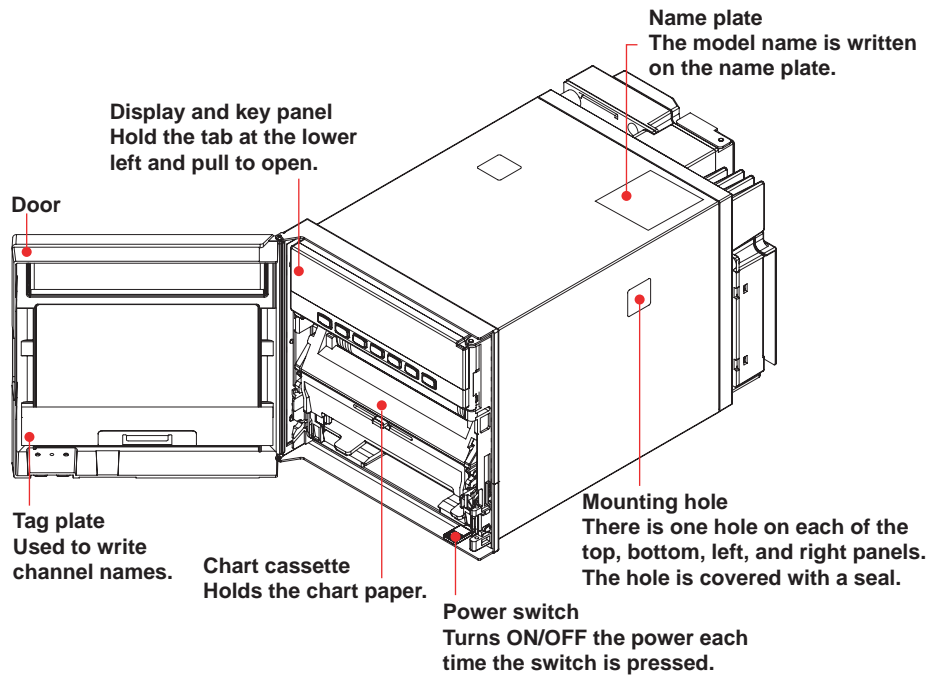

**Pen model**

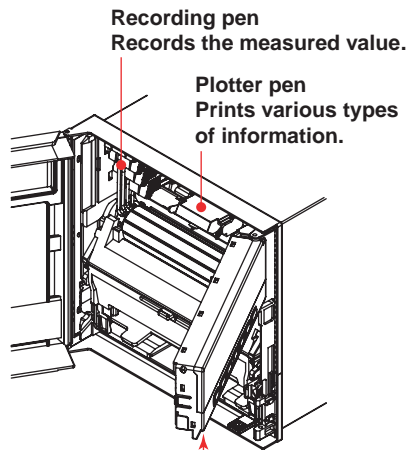

**Dot model**

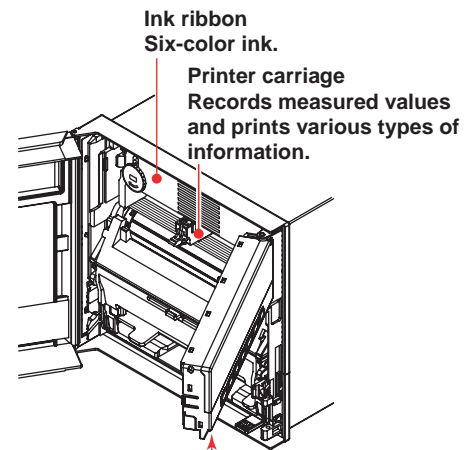

**Display and key panel (see the next page)**  
There is an internal light on the bottom section of the display and key panel. It lights up the recording area of the chart paper.

**Rear Panel**

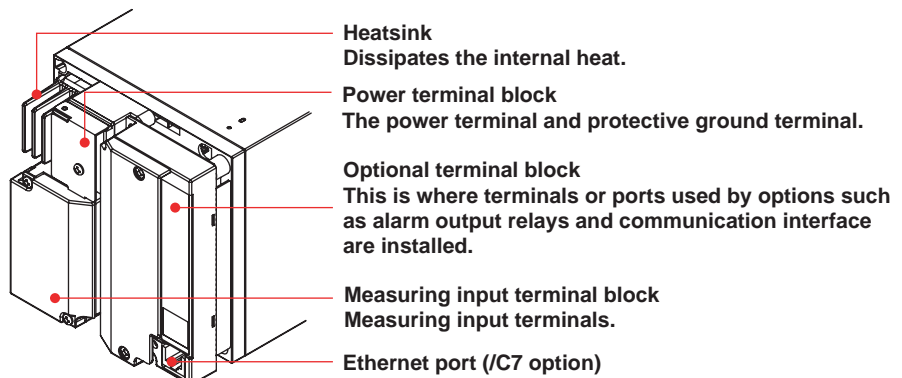

## Display and Key Panel

### Status display

Displays the following information.

- RECORD Illuminates while recording measured values.
- KEY LOCK Illuminates when key lock is enabled.
- MATH Illuminates when computation on the computation function (/M1 option) is in progress.
- CHART END Illuminates when the chart paper is out (/F1 option).
- ALARM 1 to 6 Illuminates when an alarm is occurring on channels 1 to 6.

### Main display

Displays the measured values. Also, displays the setup screen when setting functions.

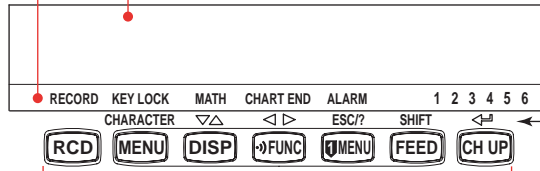

Seven keys are available.

For all keys except RCD, functions marked above the keys are enabled when setting functions or when the FUNC key or the DISP MENU key is pressed.

<While setting functions, when the FUNC key/DISP MENU key is pressed>

**CHARACTER Key:** Changes the character type when entering a character. Press this key while holding down the SHIFT key to switch the character type in reverse order.

**UP/DOWN Key:** Switches the setup item or the value.

Press this key while holding down the SHIFT key to switch the setup item or the value in reverse order.

**LEFT/RIGHT Key:** Moves the cursor to the right when entering a value or character. Press this key while holding down the SHIFT key to move the cursor to the left.

**ESC Key:** Cancels the operation.

When pressed with the SHIFT key, the display of the comment on the setting turns ON/OFF.

**SHIFT Key:** Used with the ∇Δ key, <|> key, the CHARACTER key, or the ESC key.

**ENTER Key:** Confirms the setup item or value.



<During normal operation>

**CH UP key**  
Switches the displayed channel.  
(when manual switching is specified)

**FEED key**  
Feeds the chart paper.

**DISP MENU key**  
Hold this key down for 3 seconds to switch to the data display setup screen. Hold this key down for 3 seconds also to exit from the data display setup screen.

**FUNC key**  
Used when executing manual printout, message printout, etc.

**DISP key**  
Switches the screen in the main display.

**MENU key**  
Hold this key down for 3 seconds to enter Setting mode. Hold this key down for 3 seconds also to exit from Setting mode.

**RCD key**  
Starts/stops recording.

# Installing/Wiring the Recorder

## Installation Location

Install the recorder indoors in a location that meets the following conditions.

- **Instrument Panel**  
The recorder is designed for panel mounting.
- **Well-Ventilated Location**  
To prevent overheating, install the recorder in a well-ventilated location.  
For the panel cut dimensions when arranging multiple recorders, see the next page.  
Follow the panel cut dimensions providing adequate space between instruments when other instruments are arranged on the panel.
- **Minimum Mechanical Vibrations**  
Choose an installation location with the minimum mechanical vibration.  
Installing the recorder in a location with large mechanical vibration not only causes adverse effects on the mechanism but also may hinder normal recording.
- **Horizontal**  
Install the recorder horizontally (However, the recorder can be inclined up to 30 degrees backwards for panel mounting).

### Note

- Condensation may occur if the recorder is moved to another place where both the ambient temperature and humidity are higher, or if the temperature changes rapidly. In addition, measurement errors will result when using thermocouples. In this case, let the recorder adjust to the new environment for at least one hour before using it.
- The chart paper may be adversely affected by a rapid change in the ambient temperature and humidity.

Do not install the recorder in the following places.

- **Outdoors**
- **In Direct Sunlight or Near Heat Sources**  
Install the recorder in a place with small temperature fluctuations near room temperature (23°C). Placing the recorder in direct sunlight or near heat appliances can cause adverse effects on the internal circuitry.
- **Where an Excessive Amount of Soot, Steam, Moisture, Dust, or Corrosive Gases Are Present**  
Soot, steam, moisture, dust, and corrosive gases will adversely affect the recorder. Avoid such locations.
- **Near Strong Magnetic Field Sources**  
Do not bring magnets or instruments that produce electromagnetic fields close to the recorder. Operating the recorder in strong magnetic fields can cause errors in the measurements.

## Installation Procedure

The recorder should be mounted on a steel panel of thickness 2 mm to 26 mm.

1. Insert the recorder from the front side of the panel (see the mounting diagram on the next page).
2. Mount the recorder to the panel using the mounting brackets that come with the package.
  - Use two brackets to support the top and bottom or the left and right sides of the case (remove the seal that is covering the holes for the mounting brackets beforehand).
  - The proper torque for tightening the mounting screws is 0.7 to 0.9 Nm.
  - Mount the recorder to the panel according to the procedure below.
    - First, attach the two mounting brackets and temporarily fasten the attachment screws.

- Next, fix the recorder in place by tightening the attachment screws with the appropriate torque. When the recorder is approximately perpendicular to the panel as you fasten the screws, press the mounting bracket against the case so that they are in contact with each other.

**CAUTION**

Tightening the screws too much can deform the case or damage the bracket.

**Panel Mounting Diagram**

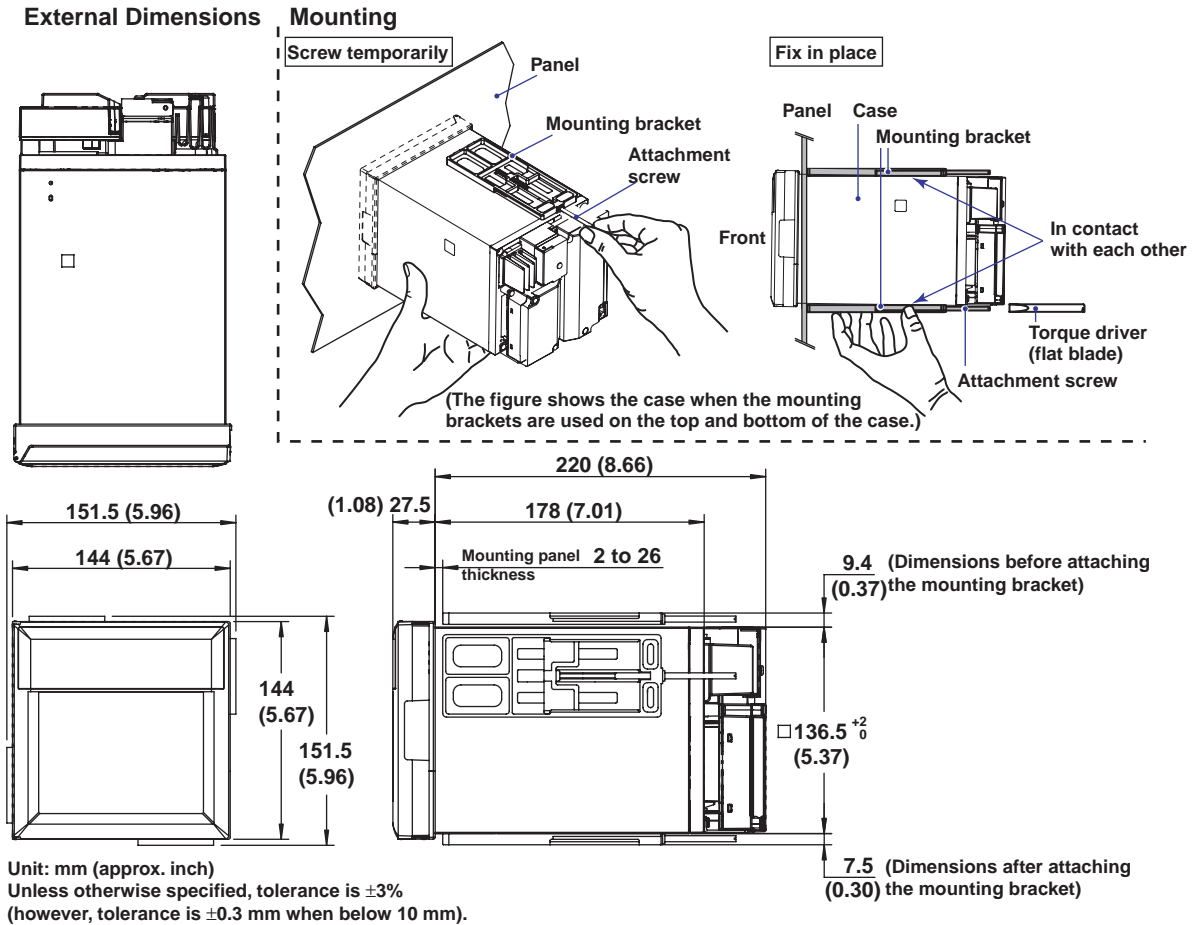

**Panel Cutout**

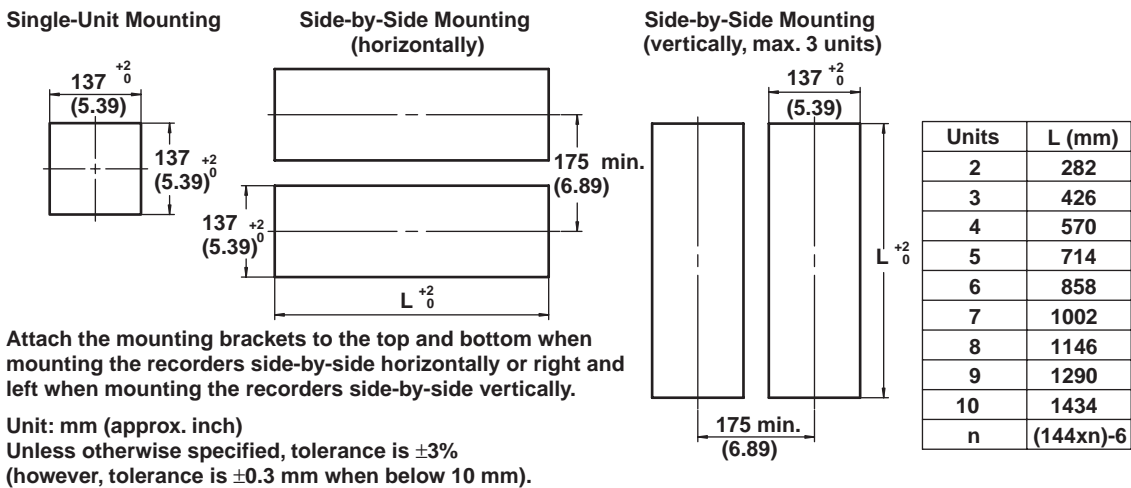

## Input Signal Wiring



### WARNING

- To prevent electric shock while wiring, ensure that the power supply source is turned OFF.

### CAUTION

- If a strong tension is applied to the cable wired to the recorder, the terminals of the recorder and/or the cable can be damaged. In order to prevent tension from being applied directly on the terminals, fasten all wiring cables to the rear of the mounting panel.
- Do not apply a voltage exceeding the following value to the input terminals as this may damage the recorder.
  - Maximum input voltage  
Voltage range less than or equal to 200 mVDC, TC, RTD, and DI:  $\pm 10$  VDC  
Ranges other than those listed above:  $\pm 60$  VDC
  - Maximum common-mode voltage  
 $\pm 60$  VDC (under measurement category II conditions)
- The recorder is an INSTALLATION CATEGORY II product.

### Precautions to Be Taken While Wiring

Take the following precautions when wiring the input signal cables.

**It is recommended that crimp-on lug with insulation sleeves (designed for 4-mm screws) be used when connecting the input/output signal wires to the terminals. However, this does not apply clamped terminals (H2).**



— Crimp-on lug with insulation sleeves (for 4 mm screws)

**For clamped terminals (H2), the following wire is recommended.**

- Conductive cross-sectional area for single wire:  $0.14 \text{ mm}^2$  to  $1.5 \text{ mm}^2$ , stranded wire:  $0.14 \text{ mm}^2$  to  $1.0 \text{ mm}^2$
- Length of the stripped section of the wire: Approx. 5 mm

**Take measures to prevent noise from entering the measurement circuit.**

- Move the measurement circuit away from the power cable (power circuit) and ground circuit.
- It is desirable that the object being measured does not generate noise. However, if this is unavoidable, isolate the measurement circuit from the object. Also, ground the object being measured.
- Shielded wires should be used to minimize noise caused by electrostatic induction. Connect the shield to the ground terminal of the recorder as necessary (make sure you are not grounding at two points).
- To minimize noise caused by electromagnetic induction, twist the measurement circuit wires at short, equal intervals.
- Make sure to earth ground the protective ground terminal through minimum resistance (less than  $100 \Omega$ ).

**When using internal reference junction compensation on the thermocouple input, take measures to stabilize the temperature at the input terminal.**

- Always use the terminal cover.
- Do not use thick wires which may cause large heat dissipation (cross sectional area of  $0.5 \text{ mm}^2$  or less recommended).
- Make sure that the ambient temperature remains reasonably stable. Large temperature fluctuations can occur if a nearby fan turns ON or OFF.

**Connecting the input wires in parallel with other devices can cause signal degradation, affecting all connected devices.**

If you need to make a parallel connection, then

- Turn the burnout detection function OFF.
- Ground the instruments to the same point.
- Do not turn ON or OFF another instrument during operation. This can have adverse effects on the other instruments.
- RTDs cannot be wired in parallel.

**Wiring Procedure**

A terminal cover is screwed in place on the measuring input terminal block on the rear panel. A label indicating the terminal arrangement is affixed to the cover.

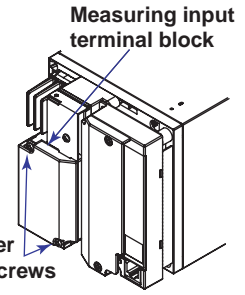

1. Turn OFF the recorder and remove the terminal cover.
2. Connect the signal wires to the terminals.

**Note**

Input signal wires of diameter less than or equal to 0.3 mm may not be secured firmly for clamped terminals (/see below). Fold over the conducting section of the wire, for example, to make sure that the wire is securely connected to the clamped terminal.

3. Replace the terminal cover and fasten it with screws.  
The proper torque for tightening the screws is 0.6 N-m.

**Pen Model**

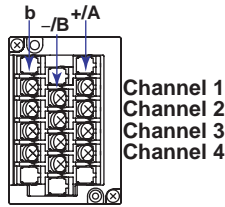

Screw input terminal

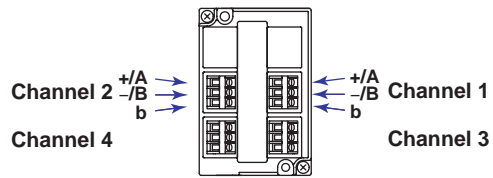

Clamped input terminal (H2)

**Dot Model**

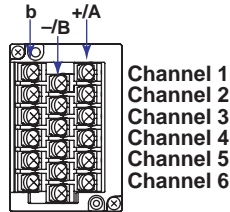

Screw input terminal

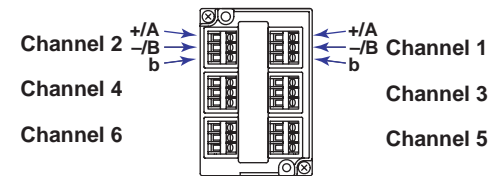

Clamped input terminal (H2)

**Measuring Input Wiring**

**Thermocouple input**

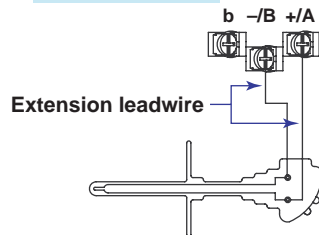

**Resistance temperature detector input**

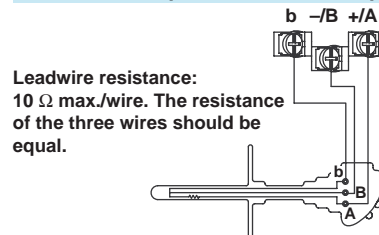

**DC voltage input, 1-5V input, and ON/OFF input**

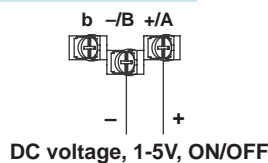

**DC current input**

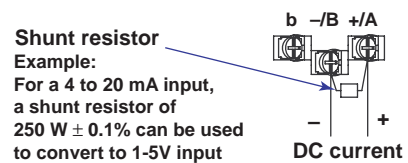

**Note**

RTD input terminals A and B on the dot model are isolated on each channel. Terminal b is shorted internally across all channels. However, for 3 legs isolated RTDs (/N2 option), input b is also isolated for each channel.

## Optional Terminal Wiring



### WARNING

- To prevent electric shock while wiring, ensure that the power supply source is turned OFF.
- If a voltage of more than 30 VAC or 60 VDC is to be applied to the output terminals, use ring-tongue crimp-on lugs with insulation sleeves on all terminals to prevent the wires from slipping out when the screws become loose. Furthermore, use double-insulated wires (dielectric strength of 2300 VAC or more) for the signal wires on which a voltage of more than 30 VAC or 60 VDC is to be applied. For all other wires, use basic insulated wires (dielectric strength of 1390 VAC). To prevent electric shock, attach the terminal cover after wiring and make sure not to touch the terminals.

### CAUTION

- To prevent fire, use signal wires having a temperature rating of 70°C or more.
- If a strong tension is applied to the cable wired to the recorder, the terminals of the recorder and/or the cable can be damaged. In order to prevent tension from being applied directly on the terminals, fasten all wiring cables to the rear of the mounting panel.

### Wiring Procedure

As shown in the figure below, the optional terminal block is located on the rear panel. The optional terminal block is provided on the recorder when an option that requires input/output is installed such as the alarm output relay (/A1, /A2, or /A3 option), FAIL/chart end output (/F1 option), and remote control function (/R1 option). A terminal cover is screwed in place on the measuring input terminal block. A label indicating the terminal arrangement is affixed to the terminal block.

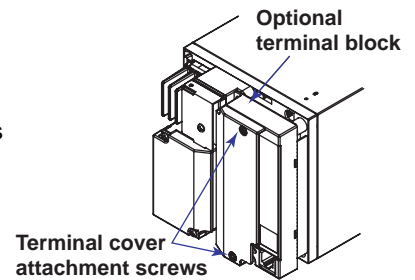

1. Turn OFF the recorder and remove the terminal cover.
2. Connect the input signal wires to the terminals.
3. Replace the terminal cover and fasten it with screws.  
The proper torque for tightening the screws is 0.6 N-m.

### Note

To reduce noise, use a shielded cable for the wiring of the remote control input terminals. Connect the shield to the ground terminal of the recorder.

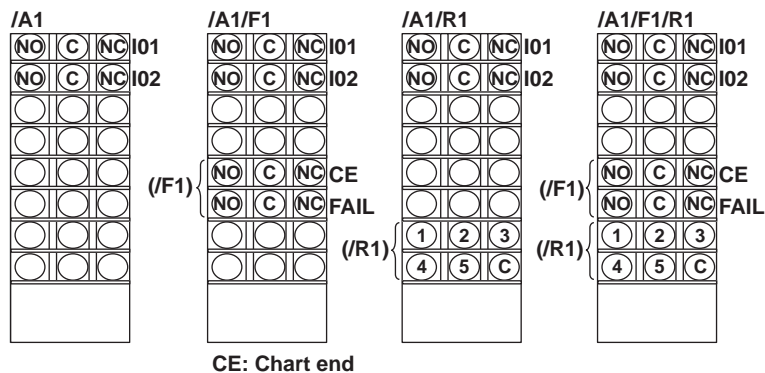



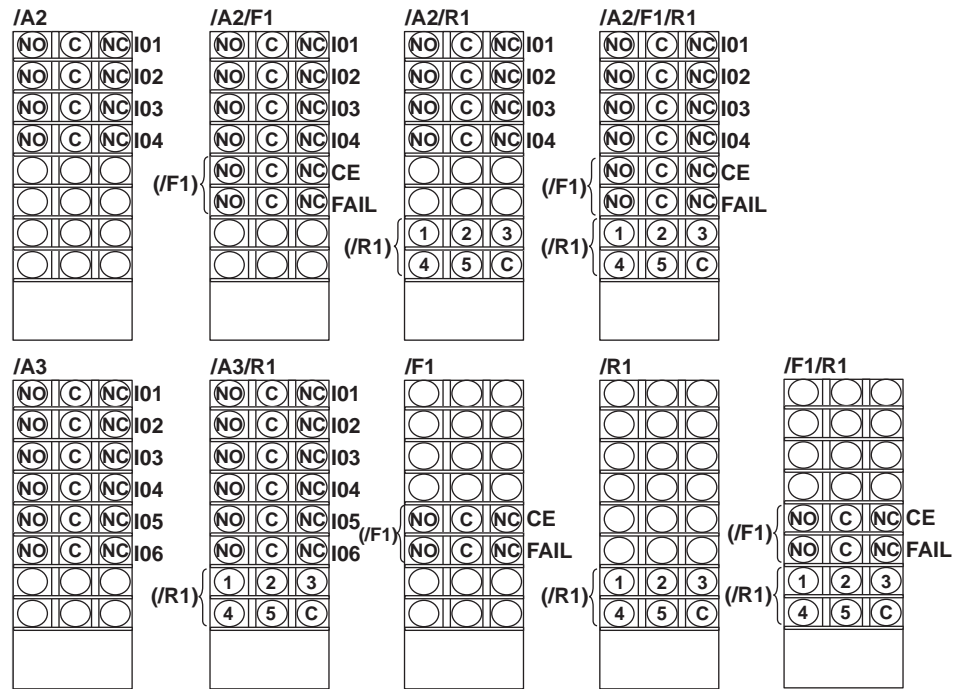

CE: Chart end

**Alarm Output Relay Terminals and FAIL/Chart End Output Relay Terminals**

NC (Normally Closed), C (Common), NO (Normally Opened)

Alarm output terminals 01 to 06 are expressed as I01 to I06 in the alarm output relay settings.

**Remote Control Input Terminals**

1 to 5 (Remote control input terminals), C (Common)

Remote control input terminals 1 to 5 are expressed as numbers 1 to 5 in the remote control input settings.

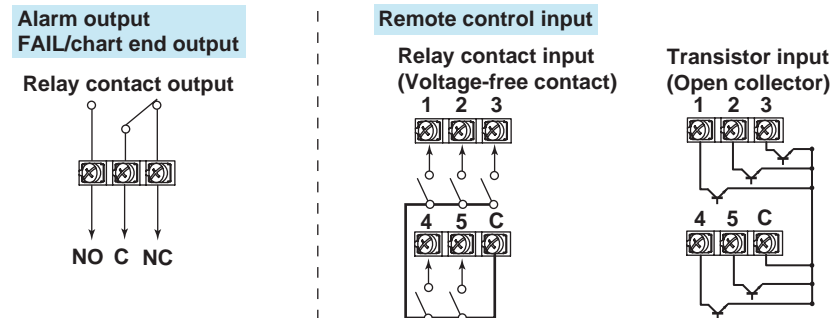

**Relay Contact Output Specifications**

- Output format: Relay contact
- Contact rating: 250 VAC (50/60 Hz)/3 A, 250 VDC/0.1 A (for resistor load)
- Dielectric strength: 1500 VAC at 50/60 Hz for one minute (between output terminals and the ground terminal)

**Relay Contact Input/Transistor Input Specifications**

- Voltage-free contact: Contact closed at 200 Ω or less and contact open at 100 kΩ or greater
- Open collector: 0.5 V or less (30 mADC) when turned ON, leakage current of 0.25 mA or less when turned OFF

Input format: Photocoupler isolation (shared common)

Dielectric strength: 500 VDC for one minute between input terminals and the ground terminal



## Power Supply Wiring



### WARNING

- To prevent electric shock when wiring, ensure the main power supply is turned OFF.
  - To prevent the possibility of fire, use 600 V PVC insulated wire (JISC3307) or an equivalent wire for power wiring.
  - Make sure to earth ground the protective earth terminal through a grounding resistance less than 100  $\Omega$  before turning ON the power.
  - Use crimp-on lugs (designed for 4 mm screws) for power and ground wiring termination.
  - To prevent electric shock, make sure to close the transparent cover for the power supply wires.
  - Make sure to provide a power switch (double-pole type) on the power supply line in order to separate the recorder from the main power supply. Put an indication on this switch as the breaker on the power supply line for the recorder and indications of ON and OFF.
- Switch specifications
- Rated power current: 1 A or more
  - Rated rush current: 60 A or more
  - Use a switch complied with IEC 60947-1, 3.
- Connect a fuse between 2 A and 15 A in the power supply line. Use a fuse approved by CSA (for the use in North America) or VDE (for the use in Europe).
  - Do not add a switch or fuse to the ground line.

Use a power supply that meets the following conditions:

Item	Power Supply Specifications
Rated supply voltage	100 to 240 VAC
Allowable power supply voltage range	90 to 132/180 to 264 VAC
Rated power supply frequency	50/60 Hz
Allowable power supply frequency range	50/60 Hz $\pm$ 2%
Maximum power consumption	Pen model: 40 VA, dot model: 40 VA

### Note

Do not use a supply voltage in the range 132 to 180 VAC, as this may have adverse effects on the measurement accuracy.

### Wiring Procedure

The power supply terminals and protective ground terminals are located on the rear panel.

1. Turn OFF the power switch on the recorder and open the power terminal cover.
2. Wire the power cord and the protective ground cord to the power supply terminals. Use ring-tongue crimp-on lugs (designed for 4 mm screws).
3. Close the power supply terminal cover and secure it with the screw. The proper torque for tightening the screws is 0.6 N·m.

### Turning ON/OFF the Power Switch

The power switch is located inside the door at the lower right. The power switch is a push button.

Press once to turn it ON and press again to turn it OFF. When the power switch is turned ON, a self-diagnosis program runs for a few seconds, and the recorder is ready for operation.

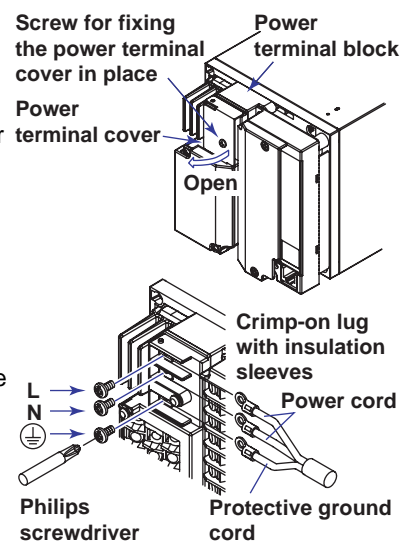

# Common Operations and Menu Structure

## Execution Modes

The recorder has three execution modes.

### Operation Mode

This mode is used for normal recording operation. The recorder enters this mode when the power is turned ON.

### Setting Mode

This mode is used to set the input range, alarms, chart speed, and other parameters. These settings can be changed while recording is in progress. However, the input range of measurement channels and the computing equation, unit, constant, and TLOG setting of computation channels cannot be changed while computation (/M1 option) is in progress.

### Basic Setting mode

This mode is used to set the basic specifications of the recorder such as the thermocouple burnout detection function and the alarm output relay operation. This mode cannot be entered while the recorder is recording or while computation is in progress on the computation function (/M1 option). Measurement, recording, and alarm detection cannot be carried out in this mode.

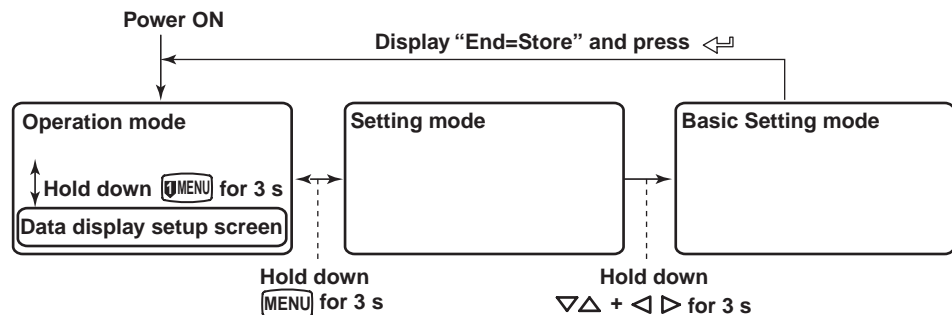

## Operation Sequence

This section explains the operations that need to be carried out when using the recorder for the first time.

### • Preparing to Record

Load the chart paper and pens (pen model) or ribbon cassette (dot model). Change the date/time if necessary.

For the operating procedure, see page 24.

### • Setting the Channel Input Range and Other Parameters

Set the measurement conditions suitable for the object being measured.

This manual explains the following operations.

- Setting the input range and alarm (see page 30 for the procedure)
- Changing the chart speed (see page 37 for the procedure)

### • Recording/Displaying Data

Start/Stop the recording operation and carry out various types of printouts. Also, switch the display screen and change the displayed contents.

For the operating procedure, see page 36.

## Key Operation

### Entering Setting Mode

Hold down the **(MENU)** key for 3 seconds.

The Setting mode display appears. The top and bottom lines are the setup item and comment, respectively.

The section that is blinking is the setup item that you change. In this manual, the section that you change appears shaded.

Setup item → **Set=Range** ← The item to be controlled blinks.  
 Comment → Input range and

In Setting mode, the panel keys are set to the functions marked above the keys.



### Exiting from Setting Mode (Returning to Operation Mode)

Hold down the **(MENU)** key for 3 seconds.

The recorder returns to operation mode.

### Entering Basic Setting Mode

Hold down the **(MENU)** key for 3 seconds to enter Setting mode. Next, hold down both the **▽△ (DISP)** key and the **◀▶ (FUNC)** key for 3 seconds.

The Basic Setting mode display appears. The top and bottom lines are the setup item and comment, respectively.

The section that is blinking in the setup item that you change.

Setup item → **Basic=Alarm** ← The item to be controlled blinks.  
 Comment → Auxiliary alarm

### Exiting from Basic Setting Mode (Returning to Operation Mode)

Press the **ESC (MENU)** key several times to return to the **Basic=** screen.

Press the **▽△ (DISP)** key to select **End** and then press the **↵ (CH UP)** key. The setup save screen appears.

**Basic=End**  
 Save Settings

Press the **▽△ (DISP)** key to select **Store** and then press the **↵ (CH UP)** key. The setting is applied, and the screen returns to Operation mode. If you select **Abort** and press the **↵ (CH UP)** key, the setting is discarded, and the screen returns to Operation mode.

**End=Store**  
 Save settings and

## Changing the Settings

### Note

The comment line shows useful information such as a description of the setup item and the range of selectable values. Read the comment and change the items as necessary.

The selected item change each time you press the  $\nabla\Delta$  (DISP) key. The selected item change in reverse order if you press the  $\nabla\Delta$  (DISP) while holding down the **SHIFT** (FEED) key.

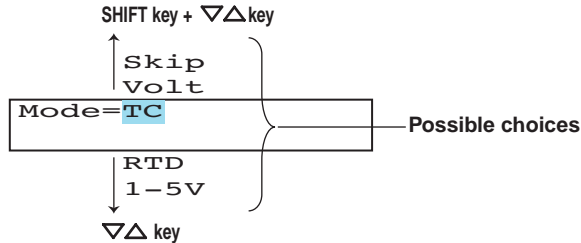

This manual denotes the operation of pressing a key while holding down the **SHIFT** (FEED) key as **SHIFT** + the other key (for example: **SHIFT** +  $\nabla\Delta$  key).

After you make a selection, press the  $\leftarrow$  (CH UP) key. The next screen appears. When the **Setting complete** screen is displayed, the changed item is applied.

```
01-01 Channel
Setting complete
```

## Using the ESC Key

If you press the **ESC** (MENU) key, the operation is cancelled, and the display returns to a higher level menu. In other words, if you do not show the **Setting complete** screen, the changes you made up to that point are discarded.

Press the **ESC** (MENU) key while holding down the **SHIFT** (FEED) key to show or hide the comment that is displayed at the bottom half of the screen.

## Entering Values

Press the  $\leftarrow$  (FUNC) key to move the cursor to the right. Press the **SHIFT** (FEED) +  $\leftarrow$  (FUNC) to move the cursor to the left.

Press the  $\nabla\Delta$  (DISP) key to increment the value. Press the **SHIFT** (FEED) +  $\nabla\Delta$  (DISP) key to decrement the value.

You repeat these steps to enter the value.

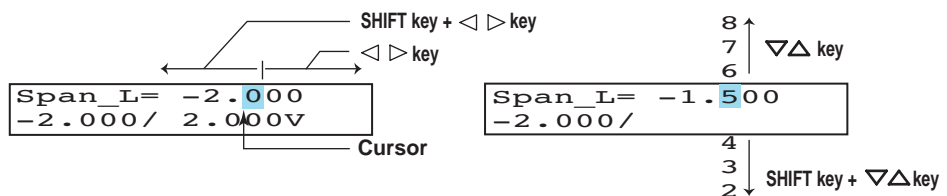

When you press the  $\leftarrow$  (CH UP) key, the change is applied and the next screen is displayed.

### Entering Characters

Press the  $\triangleleft \triangleright$  (FUNC) key to move the cursor to the right. Press the **SHIFT** (FEED) +  $\triangleleft \triangleright$  (FUNC) to move the cursor to the left.

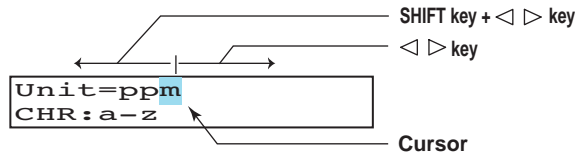

The character type changes each time you press the **CHARACTER** (MENU) key. The character type changes in reverse order each time you press the **SHIFT** (FEED) + **CHARACTER** (MENU) key.

The character type changes in the following order: uppercase alphabet, lowercase alphabet, numbers, and symbols.

The character changes each time you press the  $\nabla \triangle$  (DISP) key. The character changes in reverse order each time you press the **SHIFT** (FEED) +  $\nabla \triangle$  (DISP) key.

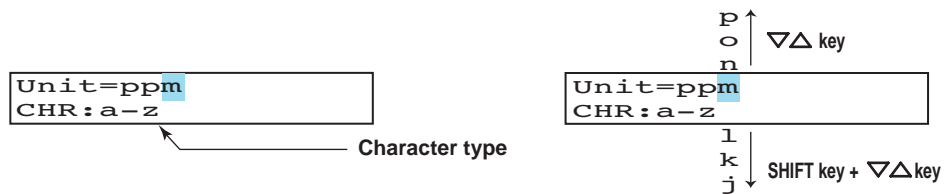

You repeat these steps to enter the character.

When you press the  $\triangleleft \triangleright$  (CH UP) key, the change is applied and the next screen is displayed.

- **Inserting a Character**

Press the  $\triangleleft \triangleright$  (FUNC) key to move the cursor to the position where the character is to be inserted.

Press the  $\nabla \triangle$  (DISP) key to show **Ins DISP** and then press the  $\nabla \triangle$  (DISP) key. A space for one character is inserted. Enter the character.



- **Deleting a Character**

Use the  $\triangleleft \triangleright$  (FUNC) key to move the cursor to the character to be deleted.

Press the **CHARACTER** (MENU) key to show **Del DISP** and then press the  $\nabla \triangle$  (DISP) key. The character is deleted.

- **Deleting an Entire Character String**

Press the **CHARACTER** (MENU) key to show **Clear DISP** and then press the  $\nabla \triangle$  (DISP) key. The entire character string is deleted.

- **Copying & Pasting a Character String**

Show the copy source character string.

Press the **CHARACTER** (MENU) key to show **Copy DISP** and then press the  $\nabla \triangle$  (DISP) key. The character string is saved to the memory.

Show the copy destination.

Press the **CHARACTER** (MENU) key to show **Paste DISP** and then press the  $\nabla \triangle$  (DISP) key. The character string is pasted.

\* When the  $\triangleleft \triangleright$  (FUNC),  $\nabla \triangle$  (DISP), or **CHARACTER** (MENU) key is pressed while holding down the **SHIFT** (FEED) key, the operation is reversed as when the respective key is pressed by itself.

### Menu Structure of Setting Mode

References to the *Industrial Chart Recorder User's Manual* (9499-040-82011) are given in parentheses.



### Menu Structure of Basic Setting Mode

References to the *Industrial Chart Recorder User's Manual* (9499-040-82011) are given in parentheses.

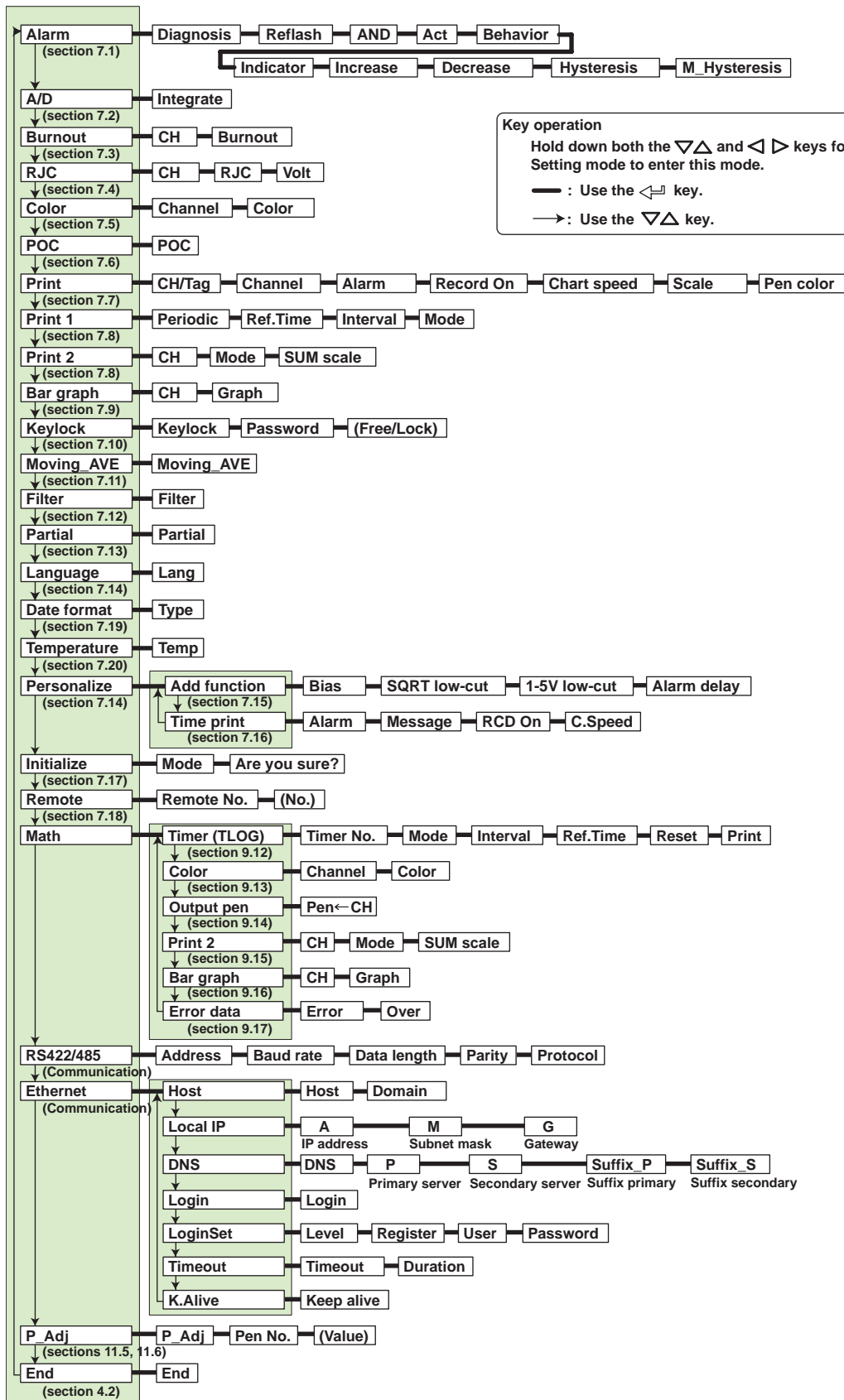

**Key operation**  
 Hold down both the  $\nabla$  and  $\triangle$  keys for 3 seconds in Setting mode to enter this mode.  
 ← : Use the  $\leftarrow$  key.  
 → : Use the  $\rightarrow$  key.

# Preparing to Record

## Loading or Replacing the Chart Paper

### CAUTION

- Do not install or remove the chart cassette with the chart paper guide open. This may damage the stopper.
- Continuing to record or print without the chart paper on the dot model can cause damage to the chart cassette platen (the cylindrical section that holds the paper during the recording operation). Be sure to replace the chart paper ahead of time.

### Loading the Chart Paper

1. Open the door.  
If recording is in progress, press the **RCD** key to stop the recording.
2. Remove the chart cassette.  
Gently pressing the left and right stoppers inward. The bottom section of the chart cassette comes out. Gently lift the chart cassette and pull it out from the recorder case.

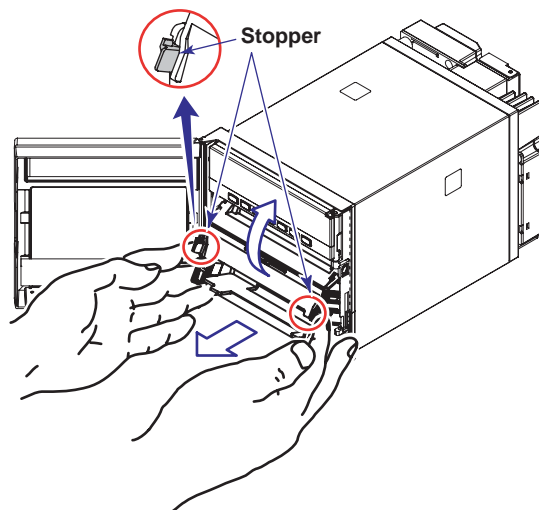

3. Open the chart holder and the chart paper guide.

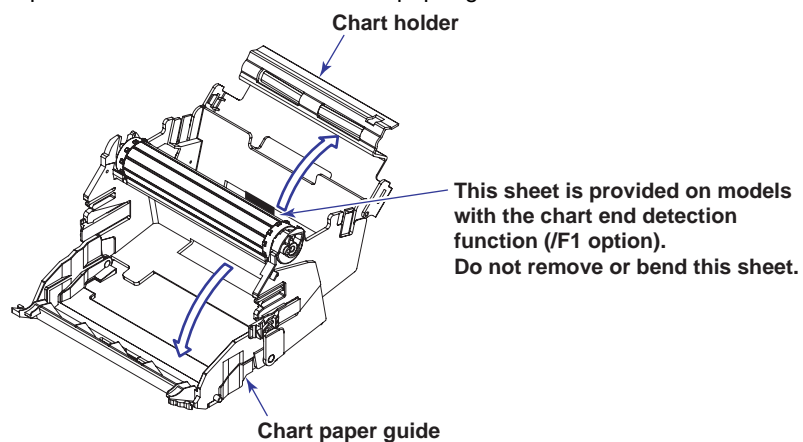



4. Load the chart paper.  
Riffle the chart thoroughly before loading. Make sure that the sprocket teeth of the chart drives are properly engaged in the chart paper perforations. Make sure not to load the chart paper backwards.

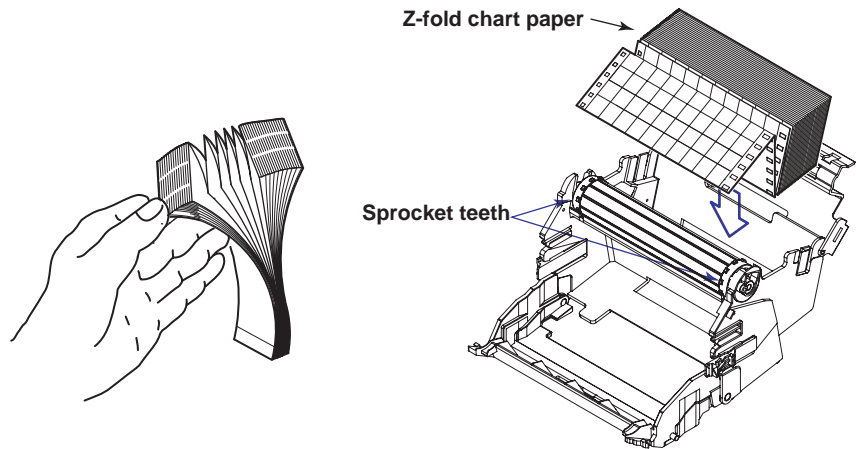

5. Close the chart holder and close the chart paper guide.

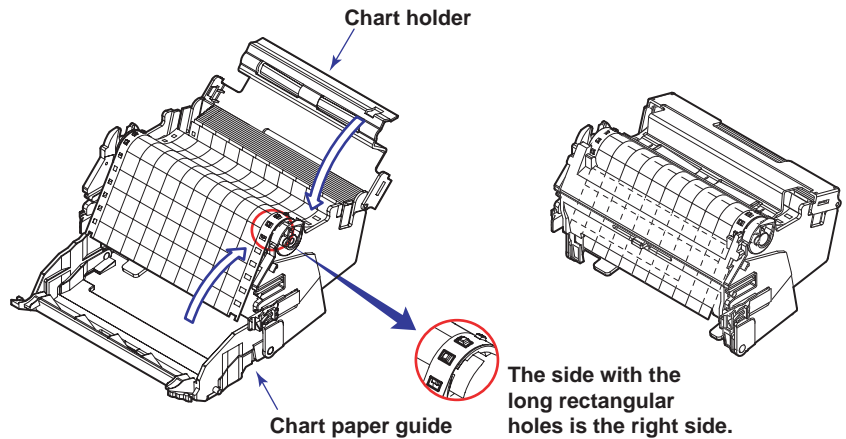

6. Replace the chart cassette back into the recorder.  
Align the left and right projections with the guide grooves of the recorder and press the entire chart cassette into the recorder case. The chart cassette is fixed in place with the stoppers.

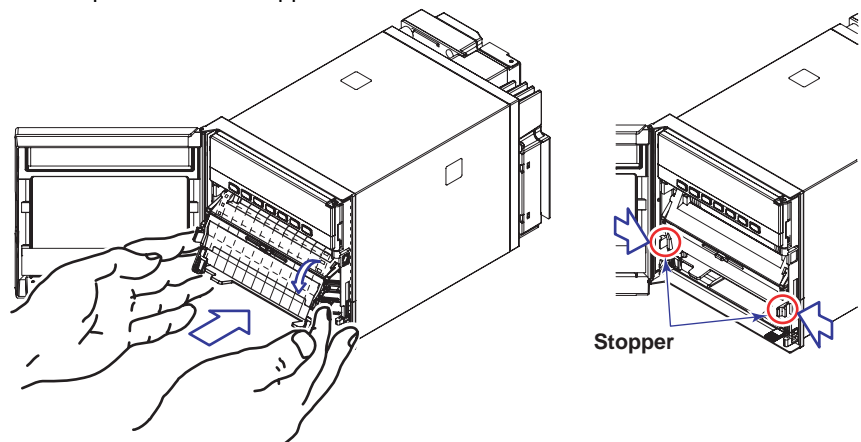

#### Feeding the Chart Paper

7. Press the **FEED** key to assure that the chart moves two or more folds smoothly into the chart receiver.  
If it moves unsteadily, do the installing procedure again.

## Installing/Replacing Felt Pens (Pen Model)

### CAUTION

- Do not press or pinch the felt tip to prevent deformation.
- Do not move the penholder left or right by force to protect the driving mechanism.
- Make sure to remove the pen cap before installation.
- Use pen caps of the same ink color. If a pen cap of a different ink color is used on the pen, the remaining ink in the cap may be absorbed through the pen tip, and the ink may change its color.

1. Open the door.  
If recording is in progress, press the **(RCD)** key to stop the recording.
2. Open the display and key panel section.  
You can open the display and key panel section by holding the tab at the lower left and pulling it toward you.
3. Hold the felt pen cartridge and pull it out from the pen holder.  
If the pen (pen holder) is at a position that is not easily accessible, see “When the Pen (Pen Holder) Is at a Position That Is Not Easily Accessible” below.
4. Remove the cap from the new felt pen and insert the pen firmly into the pen holder.

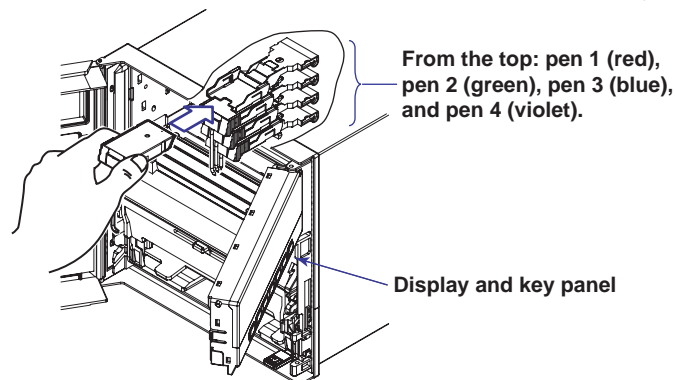

5. Return the display and key panel section to its original position.

### When the Pen (Pen Holder) Is at a Position That Is Not Easily Accessible

If the pen (pen holder) is at a position that is not easily accessible, carry out the procedure below to move it near the center position.

1. Press the **(FUNC)** key.
2. Press the **(DISP)** key several times to display the Pen exchange screen.  

3. Press the **(CH UP)** key.  
The pen (pen holder) moves near the center position, and the **Pen exchange = End** screen appears.

### Note

When the pen moves, a line is drawn on the chart paper.

4. Replace the pen.
5. Return the display and key panel section to its original position, and press the **(CH UP)** key.  
The screen returns to the data display screen.

\* When the **(CH UP)** key or **(DISP)** key is pressed while holding down the **SHIFT** key, the operation is reversed as when the respective key is pressed by itself.

### Installing/Replacing the Plotter Pen (Pen Model)

1. Open the door.  
If recording is in progress, press the **RCD** key to stop the recording.
2. Open the display and key panel section.
3. Hold the plotter pen cartridge and pull it out from the pen holder.
4. Remove the cap from the new plotter pen and insert the pen firmly into the pen holder.

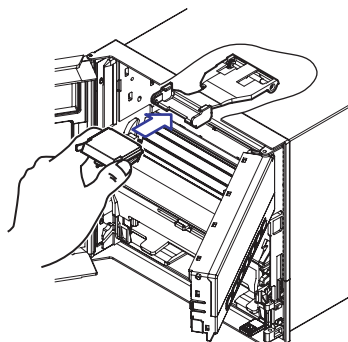

5. Return the display and key panel section to its original position.

### Installing/Replacing the Ribbon Cassette (Dot Model)

#### CAUTION

- Improper cassette insertion may cause the color to change or damage the ribbon.
- Do not apply upward force to the printer carriage. If you do, the carriage position may be offset, and the recorder may not print correctly.

1. Open the door.  
If recording is in progress, press the **RCD** key to stop the recording.
2. Press the **→FUNC** key.
3. Press the **▽△ (DISP)** key several times to display **R.exchange**.  

Func=R. exchange
4. Press the **← (CH UP)** key.  
The printer carriage moves near the center position, and **R. exchange = End** is displayed.
5. Open the display and key panel section.  
You can open the display and key panel section by holding the tab at the lower left and pulling it toward you.

#### Note

If the recorder is OFF, hold the printer carriage and move it near the center position.

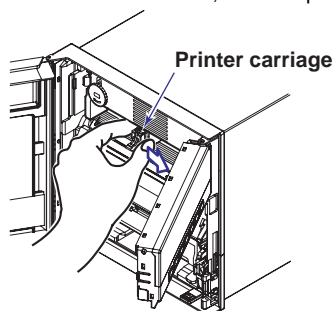

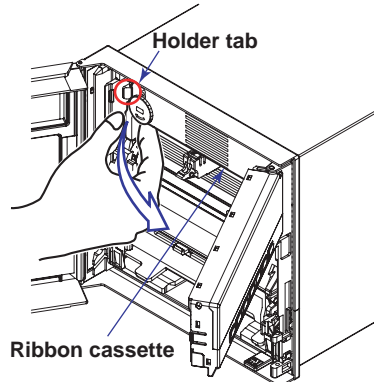

\* When the **◀▶** key or **▽△** key is pressed while holding down the **SHIFT** key, the operation is reversed as when the respective key is pressed by itself.

- 6.** Remove the ribbon cassette.  
Pull the left-hand part of the ribbon cassette so that the cassette holder tab disengages, and pull the ribbon cassette out from the recorder case.

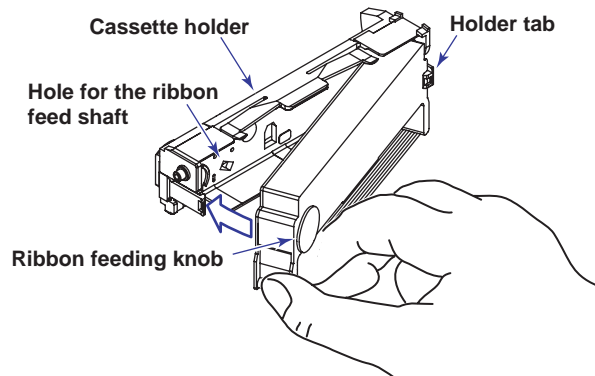

- 7.** Install a new ribbon cassette.  
First, insert the right-hand part and then the left-hand part into the cassette holder.  
Check that the cassette is properly engaged with the cassette holder tab.  
If inserting the ribbon cassette is difficult, turn the ribbon feeding knob in the direction of the arrow to align the ribbon feeding shaft of the cassette with the ribbon feeding shaft of the holder.



- 8.** Turn the ribbon feeding knob in the direction of the arrow a half turn or more to check that the ribbon is feeding properly. If the ribbon is loose, turn the knob in the direction of the arrow to tighten it.
- 9.** Return the display and key panel section to its original position, and press the  (CH UP) key.  
The screen returns to the data display screen.

## Checking or Setting the Date/Time

### Checking the Date/Time

The date/time is shown on the display when the **DISP** key is pressed several times.

### Setting the Date/Time

1. Hold down the **MENU** key for 3 seconds to enter Setting mode.
2. Press the **▽△** key to show **Clock** and then press the **↵** key.

```
Set=Clock
```

3. Set the date and time and press the **↵** key.

```
04/01/17 10:39:47 ← Year/Month/Day Hour:Minute:Second
```

Example: Changing from January to May in the figure below

Press the **◀▶** key three times to move the cursor to the month position. Next, press the **▽△** key four times to change the value from 1 to 5.

**Before change**

```
04/01/17 10:39:47
```

→

**After change**

```
04/05/17 10:39:47
```

On recorders with the version 1.02 or earlier, press the **▽△** key to select **Summer** (DST) or **Winter** (standard time), whichever the set time belongs to. Then press the **↵** key.

```
DST=Summer
```

4. When the **Setting complete** screen appears, press the **ESC/?** key.

```
Clock
Setting complete
```

5. Hold down the **MENU** key for 3 seconds to return to Operation mode.

### Explanation

The date format can be changed by date format type of basic setting mode.

\* When the **◀▶** key or **▽△** key is pressed while holding down the **SHIFT** key, the operation is reversed as when the respective key is pressed by itself.

# Setting the Input Range and Alarm on Measurement Channels

## Setting the Input Range

### Setup Example (1) of Thermocouple Input

Set channel 02 to thermocouple type K and measure temperatures in the range  $-50.0$  to  $450.0^{\circ}\text{C}$ . The measurable range for thermocouple type K is  $-200.0$  to  $1370.0^{\circ}\text{C}$ . The measured values in the range of  $-50.0$  to  $450.0^{\circ}\text{C}$  are recorded in a width of 100 mm on the chart paper. This recording range is called a *recording span*, and the leftmost and rightmost values of the recording span are called *span left* and *span right*, respectively.

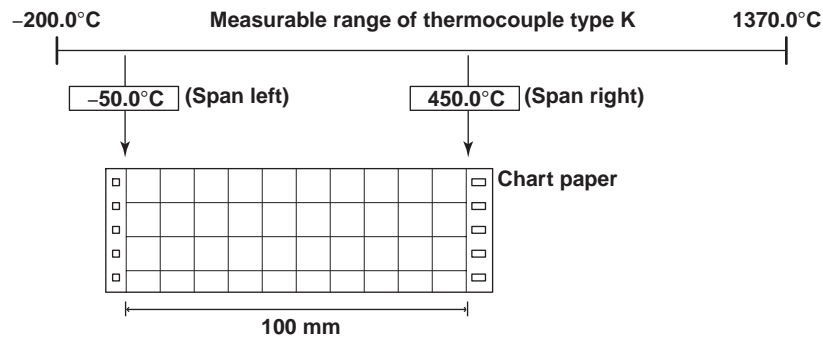

### Entering Setting Mode

1. Hold down the **MENU** key for 3 seconds to enter Setting mode.

### Selecting the Channel

2. Press the  $\leftarrow$  key with **Range** shown on the screen.

Set=Range  
Input range and ← Displays a description of the setup item.

3. Press the  $\nabla\Delta$  key to set the first channel to **02** and then press the  $\leftarrow$  key.

First channel Last channel  
CH=02-02  
First channel 01- ← Displays the selectable range of channels.

4. Likewise, set the last channel to **02** and then press the  $\leftarrow$  key.

### Selecting the Input Type

5. Press the  $\nabla\Delta$  key to select **TC** and then press the  $\leftarrow$  key (see "Explanation").

Mode=TC  
Thermocouple

6. Press the  $\nabla\Delta$  key to select **K** and then press the  $\leftarrow$  key.

Range=K  
R, S, B, K, E, J, T, N ← Displays the thermocouple type.

### Setting Span Left

7. Set Span\_L to **-50.0** and press the  $\leftarrow$  key.  
Press the  $\triangleleft$  key to select the desired digit.  
Press the  $\nabla\Delta$  key to select the value.

Span\_L=-50.0  
-200.0 / 1370.0 °C ← Displays the measurable range of thermocouple type K.

\* When the  $\triangleleft$  key or  $\nabla\Delta$  key is pressed while holding down the **SHIFT** key, the operation is reversed as when the respective key is pressed by itself.



## Setting the Input Range and Alarm on Measurement Channels

### Selecting the Input Type

5. Press the  $\nabla\Delta$  key to select **1-5V** and then press the  $\leftarrow$  key (see “Explanation”).

```
Mode=1-5V
Scales and record
```

### Setting Span Left

6. Set Span\_L to **1.000** and press the  $\leftarrow$  key.  
Press the  $\triangleleft$   $\triangleright$  key to select the desired digit.  
Press the  $\nabla\Delta$  key to select the value.

```
Span_L= 1.000
0.800 / 1.200V
```

← Displays the range of Span\_L.

### Setting Span Right

7. Likewise, set Span\_R to **5.000** and press the  $\leftarrow$  key.

```
Span_R= 5.000
4.800 / 5.200V
```

← Displays the range of Span\_R.

### Setting Scaling Left

8. Set Scale\_L to **0.0** and press the  $\leftarrow$  key.  
Press the  $\triangleleft$   $\triangleright$  key to select the desired digit.  
Press the  $\nabla\Delta$  key to select the value.

```
Scale_L= 0.0
-2000.0 / 3000.0
```

← Displays the scaling range.

### Setting Scaling Right

9. Likewise, set Scale\_R to **500.0** and press the  $\leftarrow$  key.

```
Scale_R= 500.0
-2000.0 / 3000.0
```

← Displays the scaling range.

The **Setting complete** screen is displayed. When this screen is displayed, the settings entered up to then are applied.

### Finishing the Settings

10. When **Setting complete** screen is displayed, press the **ESC** key.  
The **Set=Range** screen is displayed.

```
03-03 Channel
Setting complete
```

→

```
Set=Range
Input range and
```

### Setting the Unit

11. Press the  $\nabla\Delta$  key to select **Unit** and then press the  $\leftarrow$  key (see “Explanation”).

```
Set=Unit
Engineering unit
```

← Displays the description of setting item.

12. Press the  $\nabla\Delta$  key to set the first channel to **03** and then press the  $\leftarrow$  key.

```
First channel Last channel
    ↓           ↓
CH=03-03
First channel 01-
```

← Displays the selectable range of channels.

13. Likewise, set the last channel to **03** and then press the  $\leftarrow$  key.

### Selecting the Unit

14. Use the **CHARACTER** key and  $\nabla\Delta$  key to set **unit character** and then press the  $\leftarrow$  key (see “Explanation”).

```
Unit:
CHR: %-
```

\* When the  $\triangleleft$   $\triangleright$  key,  $\nabla\Delta$  key, or **CHARACTER** key is pressed while holding down the **SHIFT** key, the operation is reversed as when the respective key is pressed by itself.



**Finishing the Unit Setting**

15. When **Setting complete** screen is displayed, press the **ESC** key.

```
03-03 Channel
Setting complete
```

16. Hold down the **MENU** key for 3 seconds to return to Operation mode.

**Explanation**

**Note**

If the range is changed after setting the alarm, the alarm setting becomes invalid. When you change the range, check the alarm setting.

In step 5 of setup examples (1) and (2), you can select an input type or a computation type on the table below.

Mode	Description
TC	Thermocouple
RTD	Resistance temperature detector
Volt	DC voltage
DI	ON/OFF input
1-5V	1-5VDC: 1-5V is scaled to values in the appropriate unit to be used as measured values.
Delta	The value obtained by subtracting the measured value of another channel (called the reference channel) from the input value of the channel set to delta computation is used as the measured value of that channel.
Scale	The input values are scaled to values in the appropriate unit to be used as measured values.
SQRT	The square root of the input value is calculated, the result is scaled to a value in the appropriate unit, and used as the measured value of the channel. Also, the low-cut function (input less than a given measured value is fixed to 0) can be used.
Skip	Measurement is not performed.

• **Input Type and Measurable Range**

**Thermocouple (Mode: TC)**

Range Type	Measurable Range
R	0.0 to 1760.0°C
S	0.0 to 1760.0°C
B	0.0 to 1820.0°C
K	-200.0 to 1370.0°C
E	-200.0 to 800.0°C
J	-200.0 to 1100.0°C
T	-200.0 to 400.0°C
N	0.0 to 1300.0°C
W	0.0 to 2315.0°C
L	-200.0 to 900.0°C
U	-200.0 to 400.0°C
WRe	0.0 to 2400.0°C

**RTD (Mode: RTD)**

Range Type	Measurable Range
PT(Pt100)	-200.0 to 600.0°C
JPT(JPt100)	-200.0 to 550.0°C

**DC voltage (Mode: Volt)**

Range Type	Measurable Range
20mV	-20.00 to 20.00 mV
60mV	-60.00 to 60.00 mV
200mV	-200.0 to 200.0 mV
2V	-2.000 to 2.000 V
6V	-6.000 to 6.000 V
20V	-20.00 to 20.00 V
50V	-50.00 to 50.00 V

**ON/OFF input (Mode: DI)**

Range Type	Measurable Range
Level	0 to 1
Cont	0 to 1

**Characters That Can Be Used for Units**

A unit is set using up to six characters.

The available characters are as follows:

Alphabet, numbers, symbols (% , # , ° , @ , + , - , \* , / , ( , ) , μ , Ω , <sup>2</sup> , <sup>3</sup> , .), and space

## Setting the Alarm

### Setup Example

Set a high limit alarm at 400.0°C on channel 02. The relay output (option) is not available.

### Entering Setting Mode

1. Hold down the **MENU** key for 3 seconds to enter Setting mode.

### Selecting the Channel

2. Press the **↵** key with **Alarm** shown on the screen.

Set=Alarm  
Alarm setting ← Displays a description of the setup item.

3. Press the **▽△** key to set the first channel to **02** and then press the **↵** key.

First channel Last channel  
↓ ↓  
CH=01-01  
First channel 01- ← Displays the selectable range of channels.

4. Likewise, set the last channel to **02** and then press the **↵** key.

### Setting the Alarm Condition

5. Press the **▽△** key to select **1** and then press the **↵** key.

Up to four alarms can be set on a single channel. Each alarm is distinguished by its level: alarm level 1 to 4. In this example, alarm level 1 is used.

Level=1  
1-4 ← Displays the selectable range.

6. Press the **▽△** key to select **On** and then press the **↵** key.

On: Enables the alarm of the selected alarm level.

Alarm=On  
On/Off ← Displays possible choices.

7. Press the **▽△** key to select **H** and then press the **↵** key.

The letter "H" represents the high limit alarm (see "Explanation").

Type=H  
High limit alarm ← Displays a description of the selected type.

8. Set the alarm value to **400.0** by carrying out the key operations below.

Press the **< >** key to select the desired digit.

Press the **▽△** key to select the value.

When all digits have been set, press the **↵** key.

Value= 1.000  
-200.0/ 1370.0 °C ← Displays the measurable range of the input range specified on the channel.

### Setting the Relay Output

9. Since the relay output is not used, press the **↵** key with **Off** selected.

Relay=Off  
On/Off ← Displays possible choices.

The **Setting complete** screen is displayed. When this screen is displayed, the settings entered up to then are applied.

\* When the **< >** key or **▽△** key is pressed while holding down the **SHIFT** key, the operation is reversed as when the respective key is pressed by itself.

### Finishing the Settings

- 10.** When **Setting complete** screen is displayed, do either of the following:  
 Press the  $\leftarrow$  key to set other alarms.  
 To finish setting the alarm, press the **ESC** key.

```
02-02 CH/level 1
Setting complete
```

- 11.** Hold down the **MENU** key for 3 seconds to return to Operation mode.

### Explanation

In step 7, you can select an alarm type on the table below.

Type	Description
H	High Limit Alarm: An alarm occurs when the input value exceeds the alarm value.
L	Low Limit Alarm: An alarm occurs when the input value falls below the alarm value.
h	Difference High Limit Alarm*: An alarm occurs when the difference in the input values of two channels is greater than or equal to the specified value.
l	Difference Low Limit Alarm*: An alarm occurs when the difference in the input values of two channels is less than or equal to the specified value.
R	High Limit on Rate-of-Change Alarm**: The rate-of-change of the measured values is checked over a certain time (interval). An alarm occurs if the rate-of-change of the measured value in the rising direction is greater than or equal to the specified value.
r	Low Limit on Rate-of-Change Alarm**: The rate-of-change of the measured values is checked over a certain time (interval). An alarm occurs if the rate-of-change of the measured value in the falling direction is greater than or equal to the specified value.
T	Delay High Limit Alarm***: An alarm occurs when the measured value remains above the alarm value for a specified time period (alarm delay period).
t	Delay Low Limit Alarm***: An alarm occurs when the measured value remains below the alarm value for a specified time period (alarm delay period).

\* Can be specified on channels set to delta computation.

\*\* Setting change in Basic Setting mode is necessary.

\*\*\* You can select T or t when the alarm delay function is enabled in Basic Setting mode.

# Recording/Displaying Data

## Starting the Recording

Press the **RCD** key to start recording.

The status display shows the word "RECORD."

### Recording Example (Pen Model)

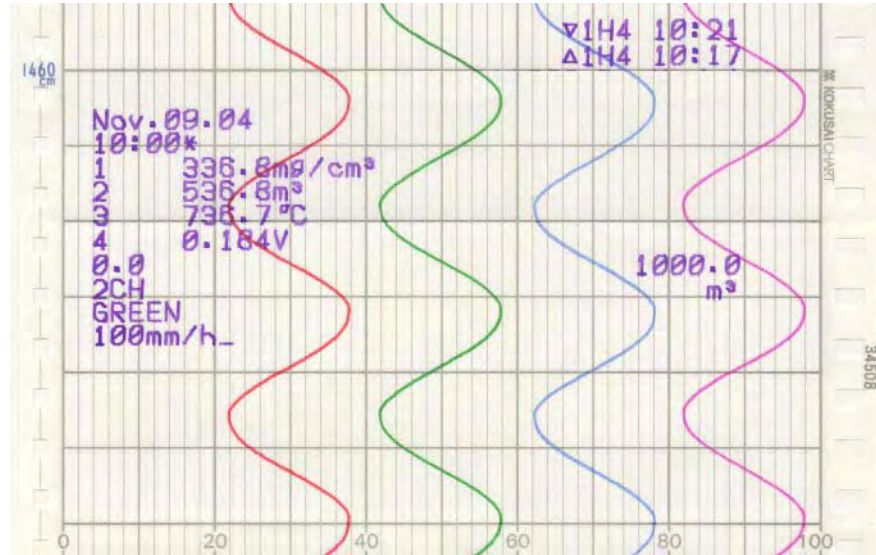

### Recording Example (Dot Model)

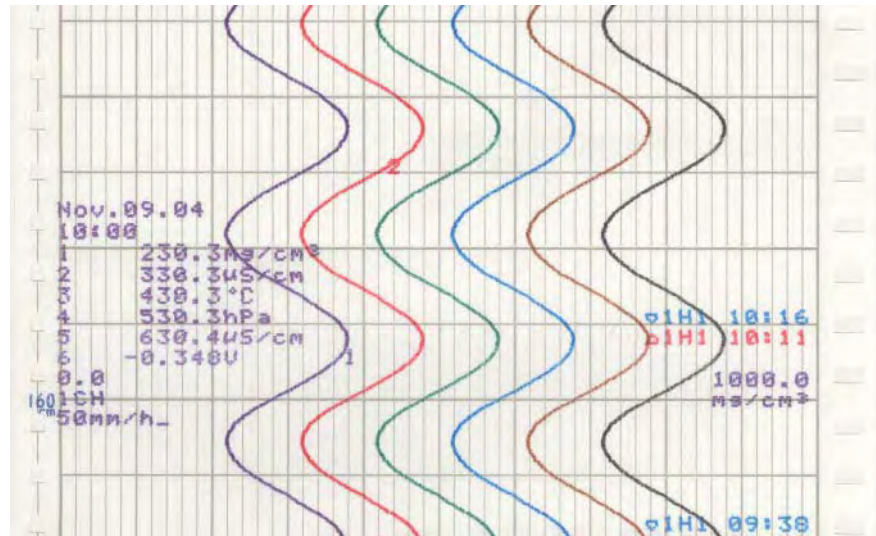

The recording examples may appear differently from the actual recording as a result of functional improvements made on the recorder after this manual was written.

## Stopping the Recording

While recording is in progress, press the **RCD** key to stop recording.

The word "RECORD" on the status display clears.

## Feeding the Chart Paper

The chart paper is fed while the **FEED** key is held down.

## Changing the Chart Speed

1. Hold down the **MENU** key for 3 seconds to enter Setting mode.
2. Press the  $\nabla\Delta$  key to show **Chart** and then press the  $\leftarrow$  key.

Set=Chart  
Chart speed ← Displays a description of the setup item.

3. Set the chart speed and press the  $\leftarrow$  key.

mm/h= 20 ← Current chart speed.  
1 / 1500mm/h ← Displays the range that can be specified.  
(Display example on the dot model)

On the pen model, press the  $\nabla\Delta$  key to select the chart speed.

### Chart speed on the pen model (unit: mm/h)

5	6	8	9	10	12	15	16	18	20
24	25	30	32	36	40	45	48	50	54
60	64	72	75	80	90	96	100	120	125
135	150	160	180	200	225	240	250	270	300
320	360	375	400	450	480	500	540	600	675
720	750	800	900	960	1000	1080	1200	1350	1440
1500	1600	1800	2000	2160	2250	2400	2700	2880	3000
3600	4000	4320	4500	4800	5400	6000	7200	8000	9000
10800	12000								

On the dot model, enter a value to set the chart speed. The chart speed can be set in the range of 1 to 1500 mm/h in 1 mm steps.

Press the  $\leftarrow$   $\rightarrow$  key to select the desired digit.

Press the  $\nabla\Delta$  key to select the value.

4. When the **Setting complete** screen appears, the new chart speed is applied.

Chart speed  
Setting complete

Press the **ESC** key to change the chart speed again.

Hold down the **MENU** key for 3 seconds to return to Operation mode.

## Viewing the Recorded Results

Pull the front cover tab of the chart cassette to open the front cover. The recorded chart paper can be pulled out for viewing.

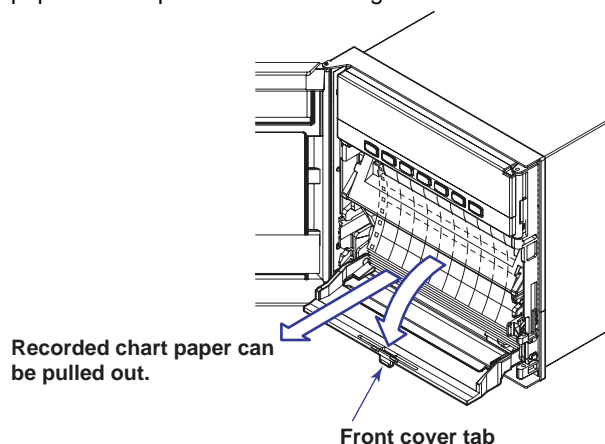

\* When the  $\leftarrow$   $\rightarrow$  key or  $\nabla\Delta$  key is pressed while holding down the **SHIFT** key, the operation is reversed as when the respective key is pressed by itself.

Description of the Printout Contents

Printout Description Figure (Pen Model)

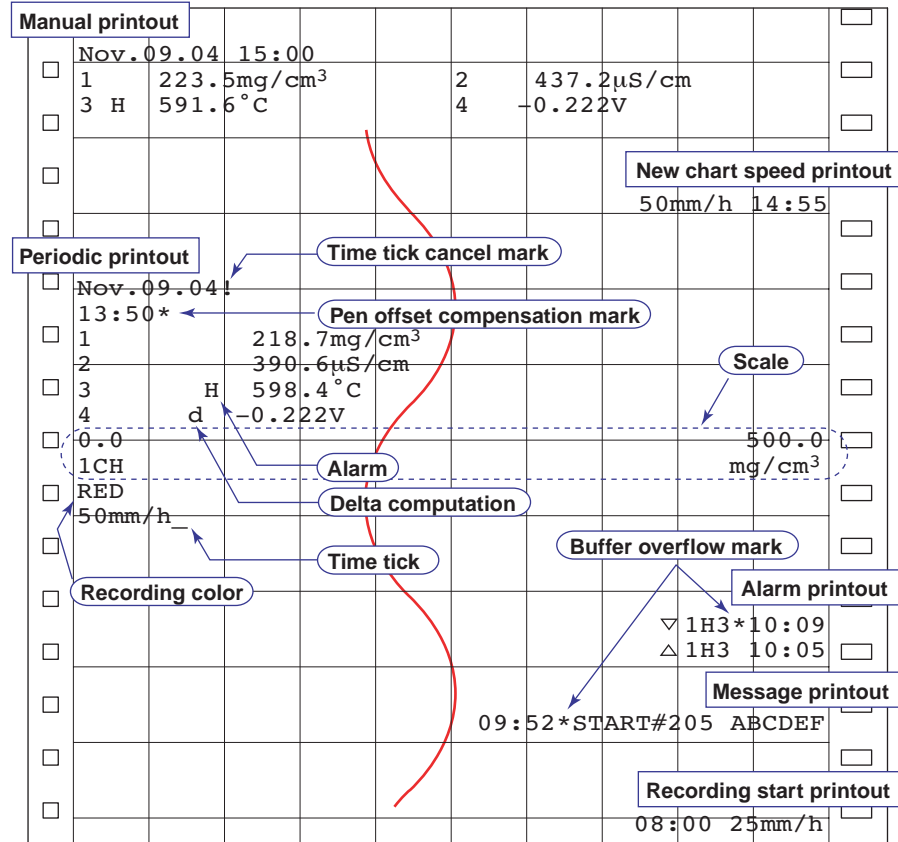

Printout Description Figure (Dot Model)

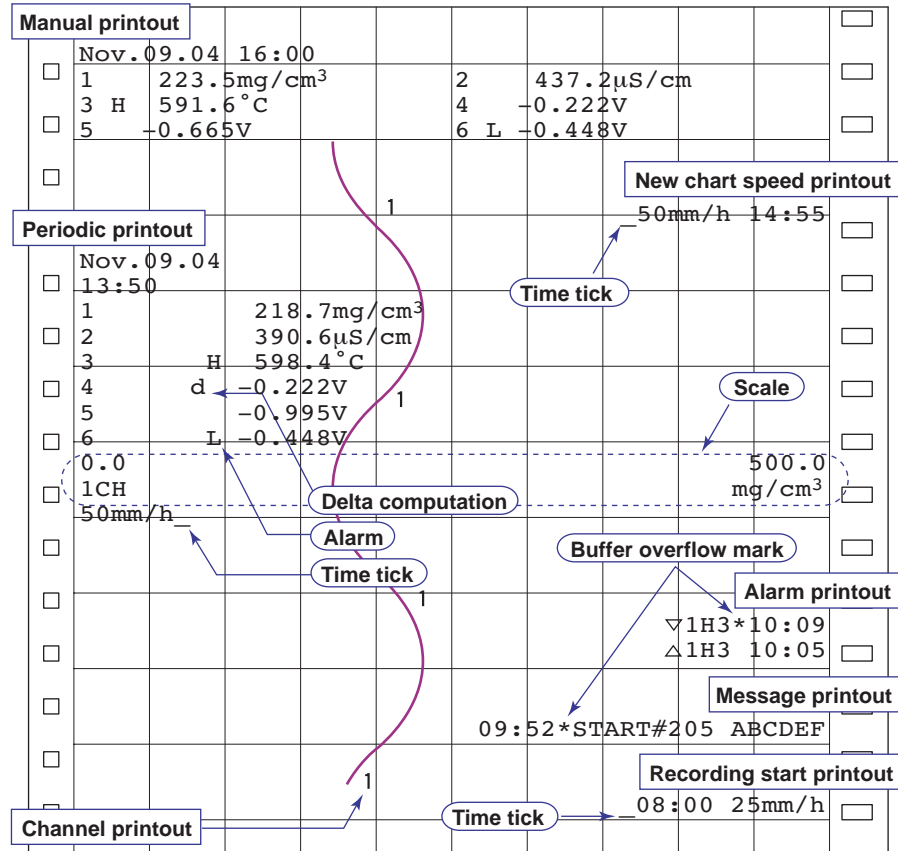

The printout description figures are for explaining the printout contents. The font is different from the actual printout. The printout positions are also slightly different.

- **Manual Printout**

Prints the current measured values and alarm statuses of all channels by operating the keys.

- **New Chart Speed Printout**

When the chart speed is changed, the time tick (dot model), the date/time of change, and the new chart speed are printed. The time ticks are marks that indicate the positions of the date/time on the chart paper. An asterisk (\*) shows there are messages that cannot be printed.

- **Periodic Printout**

Measured values and other items are printed at the preset interval.

- **Printout Contents**

The date/time, time tick, measured value and channel status for each channel, the channel scale (the leftmost and rightmost values of the span), and the chart speed are printed. On the pen model, if a time tick is not printed at the correct position, a time tick cancel mark (!) is printed. Pen offset compensation mark is printed when the function to compensate the pen offset along the time axis is enabled. For details on the printout contents, see appendix 1 in the *Industrial Chart Recorder User's Manual* (9499-040-82011) on the CD-ROM.

- **Printout Interval**

The printout interval can be set by specifying the value or set automatically in sync with the chart speed.

### Alarm Printout

Alarm information is printed when an alarm occurs or releases.

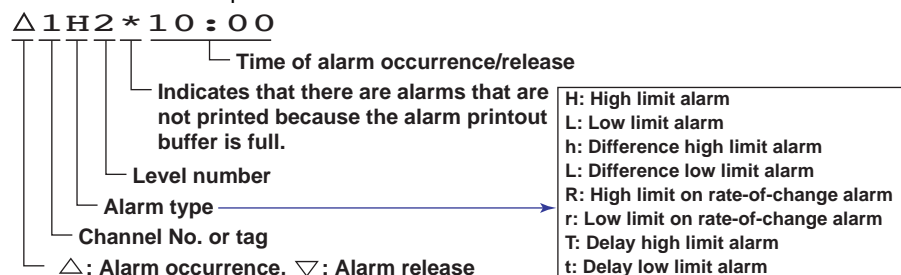

Alarms that occur while an alarm printout is in progress are temporarily saved to the buffer memory in a printout-wait condition. Alarms are cleared from the buffer memory when they are printed. A buffer overflow mark is printed when there are alarms that cannot be printed because the buffer is full.

- **Message Printout**

An arbitrary character string from five character strings set in advance can be printed on the chart paper. Each message can be set using up to 16 characters. If message printout is executed while another message is being printed, the most recent message is temporarily stored to the buffer memory in a printout-wait condition. Messages are cleared from the buffer memory when they are printed. A buffer overflow mark is printed when there are messages that cannot be printed because the buffer is full.

- **Recording Start Printout**

When recording is started, the time tick (dot model), the time, and the chart speed can be printed. By factory default, the recording start printout is disabled. An asterisk (\*) shows there are messages that cannot be printed.

- **Channel Printout (Dot Model)**

Prints the channel No. or tag by the trend recording.

### Switching the Display Screen

The screen switches each time the **DISP** key is pressed. Screen 01 through 15 are switched in order. Screens that are set to "Skip" are skipped. Below is a display example.

#### Display Example (1-channel digital + bar graph display)

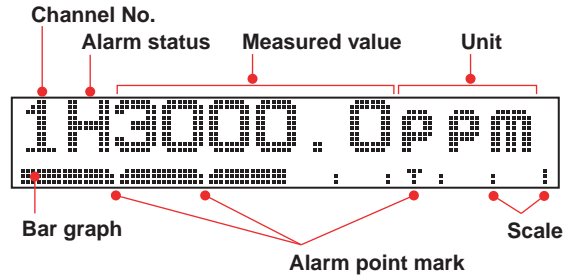

- **Channel Auto Switching**

On screens that show the measured values and computed values, the displayed channel is automatically switched in ascending order. The switching interval can be set to 1 s, 2 s, 3 s, 4 s, or 5 s.

- **Switching the Displayed Channel Using Keys**

If auto switching is not specified, the channel switches each time the **CH UP** key is pressed in ascending order. All channels are displayed in order.

#### Display Example (Flag Display)

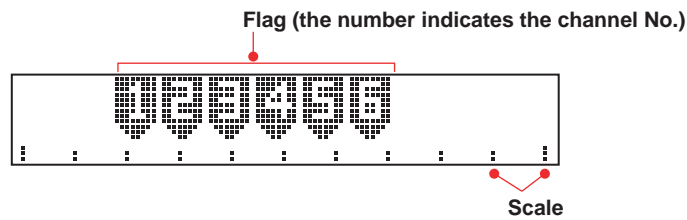

#### Display Example (Alarm Status Display)

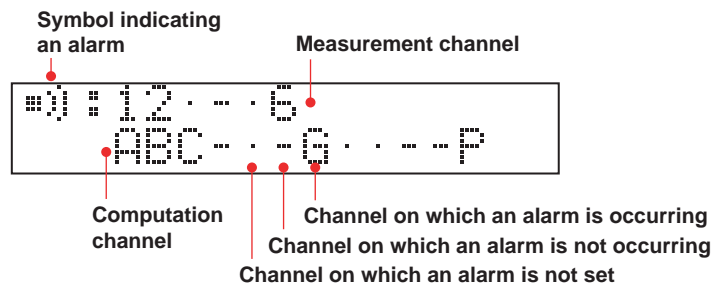

#### Display Example (Date/Time and Chart Speed Display)

The date format can be specified.

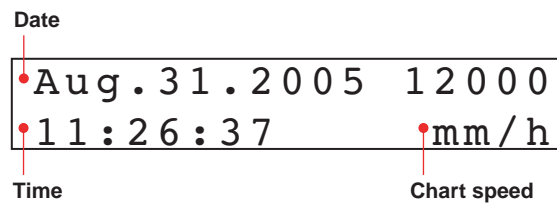

#### Display Example (Status Display)

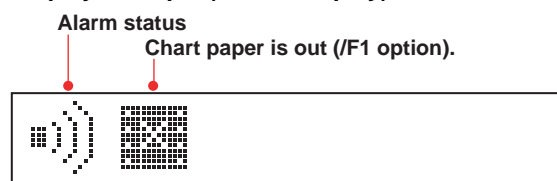



## Changing the Displayed Information

Different display types can be registered to screens 01 to 15. As an example, the procedure of assigning 1-channel digital display to screen 02 is explained below.

1. Hold the  key for 3 seconds to show the data display setup screen.

### Selecting the Screen Number

2. Press the  $\nabla\Delta$  key to select screen number **02** and then press the  $\leftarrow$  key.

Screen No.=02  Displays the current display type name.

A sample screen of the display type appears. A section of the display blinks to indicate that this is a data display setup screen.

### Selecting the Display Type

3. The display switches each time the  $\nabla\Delta$  key is pressed. Select the 1-channel digital display and then press the  $\leftarrow$  key.

1 200.0 mV

4. Press the  $\nabla\Delta$  key to set the channel switching interval and then press the  $\leftarrow$  key.

Interval: Sets the channel switching interval. Select the interval from 1 s, 2 s, 3 s, 4 s, 5 s, and manual.

Auto1s, Auto2s, Auto3s, Auto4s, Auto5s:

Switches the displayed channel at the specified time interval.

Manual: Switch the displayed channel manually.

Interval=Auto2s

5. When the **Setting complete** screen appears, the new setting is applied.







Screen No.02  
Setting complete

Press the  $\leftarrow$  key to register display types to other screens.

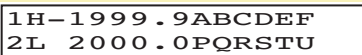
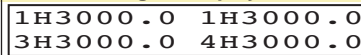
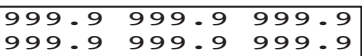
Hold the  key down for 3 seconds to exit from the data display setup screen.

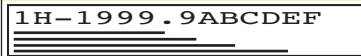
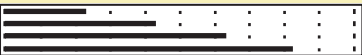
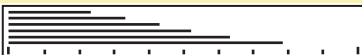
## Display Types

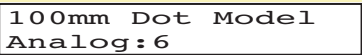
Display types listed below are available besides the types on previous page.

<b>1-channel digital display</b> 	<b>2-channel digital display</b> 	<b>4-channel digital display</b> 
<b>6-channel digital display (Dot model)</b> 	<b>2-channel digital display + 2-channel bar graph display</b> 	<b>1-channel digital display+ 4-channel bar graph display (Pen model)</b> 
<b>4-channel bar graph display (Pen model)</b> 	<b>6-channel bar graph display (Dot model)</b> 	<b>DI/DO status display</b> 
<b>System display</b> 	Switches the displayed contents every 3 seconds. Displays number of measurement inputs, optional functions, version number, etc.	<b>Lights off</b> No display.
<b>1-channel digital display (Tag display)</b> 	<b>2-channel digital display (Tag display)</b> <b>1-channel digital display + 1-channel bar graph display (Tag display)</b> <b>1-channel digital display + 4-channel bar graph display (Tag display) (Pen model)</b> <b>Multiple display (Different screens can be assigned to top and bottom sections)</b>	

\* When the  $\triangleleft\triangleright$  key or  $\nabla\Delta$  key is pressed while holding down the **SHIFT** key, the operation is reversed as when the respective key is pressed by itself.

## FUNC Key Operations in Operation Mode

The operations below can be carried out with the FUNC key in Operation mode. References to the *Industrial Chart Recorder User's Manual* (9499-040-82011) provided on the CD-ROM are given in parentheses.

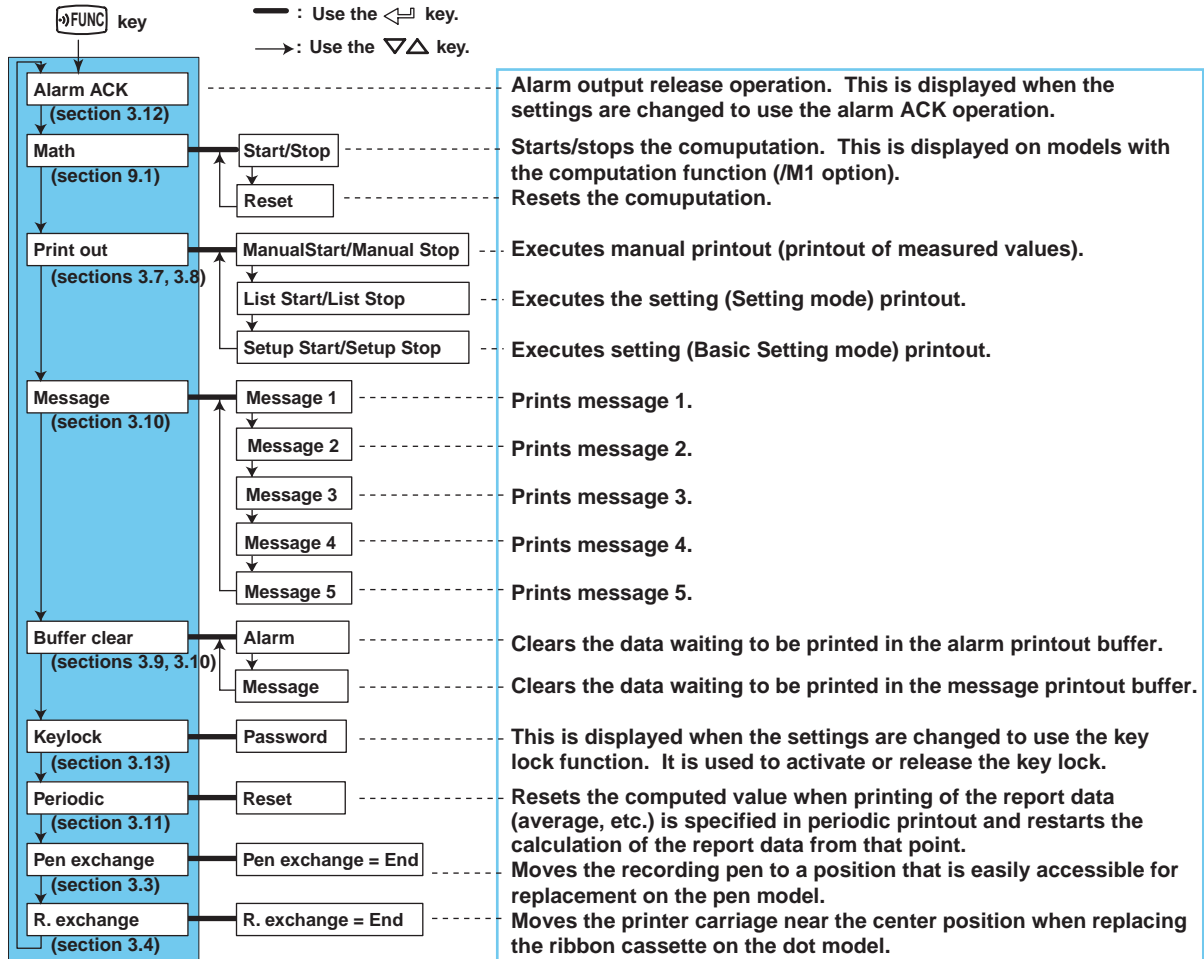

## Printing Measured Values (Manual Printout)

The measured values of all channels are printed.

### Starting the Manual Printout

1. Press the **FUNC** key.  
The **FUNC=** screen appears.
2. Press the **>** key to select **Print out** and then press the **<** key.  

```
Func=Print out
```
3. Press the **<** key with **ManualStart** shown on the screen.  
Manual printout starts. The screen returns to the data display screen.

```
Print=ManualStart
```

### Note

- When manual printout is executed, trend recording is suspended. However, the recorder continues the measurement and alarm detection (in the background).
- When manual printout is complete, trend recording resumes.
- If an alarm occurs during the manual printout, the alarm is printed after the recording resumes.

\* When the <> key or >< key is pressed while holding down the **SHIFT** key, the operation is reversed as when the respective key is pressed by itself.

### Aborting the Manual Printout

1. Press the **FUNC** key.
2. Press the **▽△** key to select **Print out** and then press the **↵** key.
3. Press the **↵** key with **Manual Stop** shown on the screen.  
Manual printout stops. The screen returns to the data display screen.

Print=Manual Stop

### Printing the Recorder Settings

This section explains the procedure for printing the recorder settings. There are two sets of settings that can be printed: List and Setup.

List: Prints the settings of Setting mode (input range for each channel, etc.)

Setup: Prints the settings of Basic Setting mode

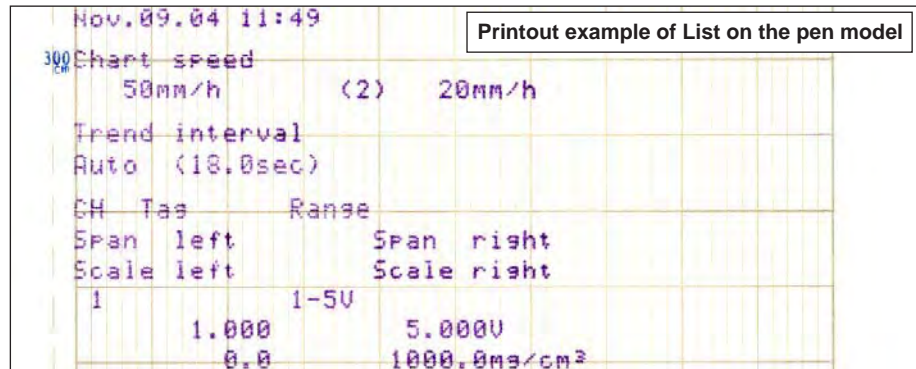

### Note

- The printout takes several minutes to tens of minutes to complete.
- When printout is executed, trend recording is suspended. However, the recorder continues the measurement and alarm detection (in the background).
- When printout is complete, trend recording resumes.
- If an alarm occurs during the printout, the alarm is printed after the recording resumes.

### Starting the List Printout

1. Press the **FUNC** key.
2. Press the **▽△** key to select **Print out** and then press the **↵** key.

Func=Print out

3. Press the **▽△** key to show **List Start** and then press the **↵** key.  
The List printout starts. The screen returns to the data display screen.

Print=List Start

### Aborting the List Printout

1. Press the **FUNC** key.
2. Press the **▽△** key to select **Print out** and then press the **↵** key.
3. Press the **▽△** key to show **List Stop** and then press the **↵** key.  
The List printout stops. The screen returns to the data display screen.

Print=List Stop

### Starting/Stopping the Setup Printout

Setup printout can be started/stopped in a similar fashion to List printout. For Setup printout, select **Setup Start** and **Setup Stop**.

\* When the **◀▶** key or **▽△** key is pressed while holding down the **SHIFT** key, the operation is reversed as when the respective key is pressed by itself.

## Clearing the Alarm Printout Buffer

Alarm information waiting to be printed is temporarily stored in the buffer memory. This operation clears all of the alarm information in the buffer. This function can be used to prevent unneeded alarm printouts from being executed.

1. Press the  key.
2. Press the  key to select **Buffer clear** and then press the  key.

```
Func=Buffer clear
```

3. Press the  key with **Alarm** shown on the screen. The data in the alarm printout buffer is cleared. The screen returns to the data display screen.

```
Buf.clear=Alarm
```

## Printing a Message

This section explains the procedure for printing the preset character strings. For details on setting the character strings, see section 6.8, "Setting the Message String" in the *Industrial Chart Recorder User's Manual* (9499-040-82011) on the CD-ROM.



### Note

- Messages can be printed only during trend recording. However, regardless of whether trend recording is in progress or not, messages waiting to be printed are temporarily stored in the buffer memory.
- Message printouts are not performed when the chart speed is greater than or equal to 1600 mm/h and 101 mm/h on the pen model and dot model, respectively.

### Printing a Message

1. Press the  key.
2. Press the  key to select **Message** and then press the  key.

```
Func=Message
```





3. Press the  key to select the message number and then press the  key. The message printout starts. The screen returns to the data display screen.

```
Message=Message1
```



← Displays the preset message.

### Clearing the Message Printout Buffer

Messages waiting to be printed are temporarily stored in the buffer memory. This operation clears the messages in the buffer.

1. Press the  key.
2. Press the  key to select **Buffer clear** and then press the  key.
3. Press the  key to select **Message** and then press the  key. The data in the message printout buffer is cleared. The screen returns to the data display screen.

```
Buf.clear=Message
```

\* When the  key or  key is pressed while holding down the **SHIFT** key, the operation is reversed as when the respective key is pressed by itself.

## Releasing the Alarm Output (Alarm ACK Operation)

This operation releases the alarm indication or relay output (/A1, /A2, or /A3 option) when the alarm indication or output relay is set to hold operation. For details on the hold operation, see section 1.3, "Alarms" in the *Industrial Chart Recorder User's Manual* (9499-040-82011) on the CD-ROM.

1. Press the **FUNC** key.
2. Press the **←** key with **Alarm ACK** shown on the screen.  
The alarm indication or relay output is released. The screen returns to the data display screen.

Func=Alarm ACK

### Description

#### Alarm ACK Operation and the Actions of the Alarm Output Relay/Alarm Display

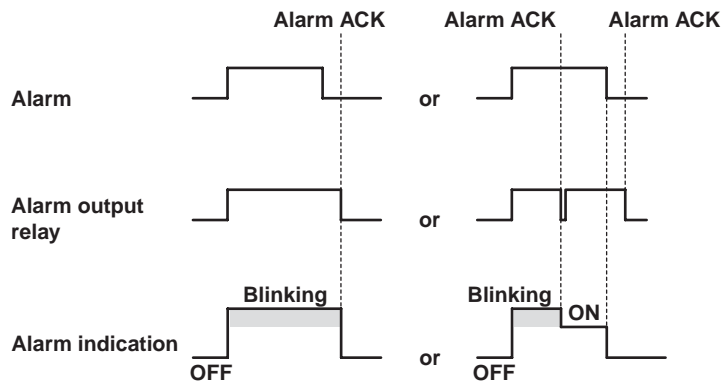

## Activating/Releasing the Key Lock

When the recorder is configured to use the key lock function, this operation activates or releases the key lock. For details on setting the key lock function, see section 7.10, "Setting the Key Lock Function" in the *Industrial Chart Recorder User's Manual* (9499-040-82011) on the CD-ROM.

### Activating the Key Lock

1. Press the **FUNC** key.
2. Press the **▽△** key to select **Keylock** and then press the **←** key.  
The key lock is activated. The screen returns to the data display screen.

### Releasing the Key Lock

#### Note

A password is required to release the key lock.

1. Press the **FUNC** key.
2. Press the **▽△** key to select **Keylock** and then press the **←** key.
3. Enter the password for releasing the key lock. The password values are shown with asterisks.  
Press the **◀▶** key to select the desired digit.  
Press the **▽△** key to select the value.

Password=

4. Press the **←** key.  
The key lock is released. The screen returns to the data display screen.

\* When the **◀▶** key or **▽△** key is pressed while holding down the **SHIFT** key, the operation is reversed as when the respective key is pressed by itself.

# Setup Items and Default Values

## Setup Items in Setting Mode and Their Default Values

The items with an asterisk are not displayed in the default condition. To display these items, settings must be changed in Basic Setting mode.

Setup Item	Pen/Dot	Selectable Range or Selections	Default Value
Range > CH	-	01 to 06	01
Range > Mode	-	Volt/TC/RTD/1-5V/Scale /Delta/DI/SQRT/Skip	Volt
Range > Mode > Range	-	20mV/60mV/200mV/2V/6V/20V/50V/1-5V /R/S/B/K/E/J/T/N/W/L/U/WRe/Pt/JPt/Level/Cont /(Selections for /N1 and /N3 options)	2V
*Bias > CH	-	01 to 06	01
*Bias > Bias	-	On/Off	Off
*Bias > Bias	-	±10 % of the span of the measurable range or the scaling span	-
Alarm > CH	-	01 to 06	01
Alarm > Level	-	1/2/3/4	1
Alarm > Alarm	-	On/Off	Off
Alarm > Type	-	H/L/h/l/R/r (*T/t)	H
Alarm > Value	-	Depends on the alarm type.	-
Alarm > Relay	-	On/Off	Off
Alarm > Relay No.	-	I01 to I06	I01
Unit > CH	-	01 to 06	01
Unit > Unit	-	6 characters or less	Blank
Chart	Pen Model	82 types (pen model)	20 mm/h
	Dot Model	1 to 1500 mm/h (dot model)	20 mm/h
Clock	-	Date/Time	-
Aux > Trend	Dot Model	Auto/Fix	Auto
Aux > Zone > CH	-	01 to 06	01
Aux > Zone > Left, Right	-	Within the recording span range (mm)	Left: 0, Right: 100
*Aux > Partial > CH	-	01 to 06	01
*Aux > Partial > Partial	-	On/Off	Off
*Aux > Partial > Expand	-	1 to 99%	50
*Aux > Partial > Boundary	-	Within the recording span range	-
Aux > Print out > CH	-	01 to 06	01
Aux > Print out > Trend	Dot Model	On/Off	On
Aux > Print out > Periodic	-	On/Off	On
Aux > Tag > CH	-	01 to 06	01
Aux > Tag > Tag	-	7 characters or less	1 to 6
Aux > Message > Message No.	-	1 to 5	1
Aux > Message > (Message)	-	16 characters or less	Blank
Aux > Chart2	Pen Model	82 types (pen model)	20 mm/h
	Dot Model	1 to 1500 mm/h (dot model)	20 mm/h
*Aux > Moving_AVE > CH	Dot Model	01 to 06	01
*Aux > Moving_AVE > No. of samples	Dot Model	Off, 2 to 16	Off
*Aux > Filter > CH	Pen Model	01 to 06	01
*Aux > Filter > Resp. Time	Pen Model	2s/5s/10s	Off
*Aux > Alm delay T > CH	-	01 to 06	01
*Aux > Alm delay T > Duration	-	0 to 3600s	10s
Aux > Brightness > Display	-	1/2/3/4/5/6/7/8	4
Aux > Brightness > Light	-	1/2/3/4	2
Aux > DST	-	Not/Use	Not
Aux > DST > Start month	-	Apr/May/June/Jul/Aug/Sep/Oct/Nov/Dec/Jan/Feb/Mar	Apr
Aux > DST > Start day	-	1st-Sun/.../Last-Mon	1st-Sun
Aux > DST > Start time	-	0:00 to 23:00	0:00
Aux > DST > End month	-	Apr/May/June/Jul/Aug/Sep/Oct/Nov/Dec/Jan/Feb/Mar	Apr
Aux > DST > End day	-	1st-Sun/.../Last-Mon	Last-Mon
Aux > DST > End time	-	0:00 to 23:00	0:00

Computation function (/M1 option)

Setup Item	Pen/Dot	Selectable Range or Selections	Default Value
Math > Formula > CH	-	0A/0B/0C/0D/0E/0F/0G/0J/0K/0M/0N/0P	0A
Math > Formula > Mode	-	On/Off	Off
Math > Formula > f.	-	120 characters or less	01
Math > Unit > CH	-	0A/0B/0C/0D/0E/0F/0G/0J/0K/0M/0N/0P	0A
Math > Unit > Unit	-	6 characters or less	Blank
Math > Constant > No.	-	K01 to K30	K01
Math > Alarm > CH	-	0A/0B/0C/0D/0E/0F/0G/0J/0K/0M/0N/0P	0A
Math > Alarm > Level	-	1/2/3/4	1
Math > Alarm > Alarm	-	On/Off	Off
Math > Alarm > Type	-	H/L (*T/t)	H
Math > Alarm > Value	-	-9999999 to 99999999 excluding the decimal	-
Math > Alarm > Relay	-	On/Off	Off
Math > Alarm > Relay No.	-	I01 to I06	I01
Math > TLOG > CH	-	0A/0B/0C/0D/0E/0F/0G/0J/0K/0M/0N/0P	0A
Math > TLOG > Timer No.	-	Periodic/1/2	Periodic
Math > TLOG > SUM scale	-	Off, /s, /min, /h, /day	Off
Math > Aux > Zone > CH	-	0A/0B/0C/0D/0E/0F/0G/0J/0K/0M/0N/0P	0A
Math > Aux > Zone > Left, Right	-	Within the recording span range (mm)	Left: 0, Right: 100
*Math > Aux > Partial > CH	-	0A/0B/0C/0D/0E/0F/0G/0J/0K/0M/0N/0P	0A
*Math > Aux > Partial > Partial	-	On/Off	Off
*Math > Aux > Partial > Expand	-	1 to 99%	50
*Math > Aux > Partial > Bound	-	Within the recording span range	-
Math > Aux > Print out > CH	-	0A/0B/0C/0D/0E/0F/0G/0J/0K/0M/0N/0P	0A
Math > Aux > Print out > Trend	Dot Model	On/Off	On
Math > Aux > Print out > Periodic	-	On/Off	On
Math > Aux > Tag > CH	-	0A/0B/0C/0D/0E/0F/0G/0J/0K/0M/0N/0P	0A
Math > Aux > Tag > Tag	-	7 characters or less	A to P
*Math > Aux > Alm delay T > CH	-	0A/0B/0C/0D/0E/0F/0G/0J/0K/0M/0N/0P	0A
*Math > Aux > Alm delay T > Duration	-	0 to 3600s	10s

Setup Items in Basic Setting Mode and Their Default Values

Setup Item	Pen/Dot	Selectable Range or Selections	Default Value
Alarm > Diagnosis	-	On/Off	Off
Alarm > Reflash	-	On/Off	Off
Alarm > AND	-	None/I01/I01-I02/I01-I03/I01-I04/I01-I05 /I01-I06	None
Alarm > Act	-	Energize/De_energize	Energize
Alarm > Behavior	-	Nonhold/Hold	Nonhold
Alarm > Indicator	-	Nonhold/Hold	Nonhold
Alarm > Increase	-	01 to 15	01
Alarm > Decrease	-	01 to 15	01
Alarm > Hysteresis	-	Off/0.1% to 1.0%	0.5%
Alarm > M_Hysteresis	-	Off/0.1% to 1.0%	Off
A/D > Integrate	-	Auto/50Hz/60Hz/100ms	Auto
Burnout > CH	-	01 to 06	01
Burnout > Burnout	-	Off/Up/Down	Off
RJC > CH	-	01 to 06	01
RJC > RJC	-	Internal/External	Internal
RJC > RJC > Volt	-	-20000 to 20000 μV	0 μV
Color > Channel	Dot Model	01 to 06	01: Purple, 02: Red,
Color > Color	Dot Model	Purple/Red/Green/Blue/Brown/Black	03: Green, 04: Blue, 05: Brown, 06: Black
POC > POC	Pen Model	On/Off	Off
Print > CH/Tag	-	CH/Tag	CH
Print > Channel	Dot Model	On/Off	On
Print > Alarm	-	On1/On2/Off	On1
Print > Record On	-	On/Off	Off
Print > Chart speed	-	On/Off	On
Print > Scale	-	On/Off	On
Print > Pen color	Pen Model	On/Off	On

## Setup Items and Default Values

Setup Item	Pen/Dot	Selectable Range or Selections	Default Value
Print1 > Periodic	-	Auto/Manual	Auto
Print1 > Ref. Time	-	Hour 0 to 23 (1 hour steps)	00:00
Print1 > Interval	-	10min/15min/20min/30min/1h/2h/3h/4h /6h/8h/12h/24h	1h
Print1 > Mode	-	Inst/Report/Off	Inst
Print2 > CH	-	01 to 06	01
Print2 > Mode	-	AVE/MIX/SUM/MIN/MAX/INST	AVE
Print2 > SUM scale	-	Off, /s, /min, /h, /day	Off
Bar graph > CH	-	01 to 06	01
Bar graph > Graph	-	Normal/Center	Normal
Keylock > Keylock	-	Not/Use	Not
Keylock > Password	-	Numbers and spaces within 4 digits	Blank
Keylock > RCD	-	Free/Lock	Free
Keylock > Feed	-	Free/Lock	Free
Keylock > Menu	-	Free/Lock	Free
Keylock > Disp Menu	-	Free/Lock	Free
Keylock > Alarm ACK	-	Free/Lock	Free
Keylock > Math	-	Free/Lock	Free
Keylock > Print out	-	Free/Lock	Free
Keylock > Message	-	Free/Lock	Free
Keylock > Buffer clear	-	Free/Lock	Free
Keylock > Periodic	-	Free/Lock	Free
Keylock > Pen exchange	Pen Model	Free/Lock	Free
Keylock > R. exchange	Dot Model	Free/Lock	Free
Moving_AVE > Moving_AVE	Dot Model	Not/Use	Not
Filter > Filter	Pen Model	Not/Use	Not
Partial > Partial	-	Not/Use	Not
Language > Lang	-	English/German/French/Japanese	English
Date format > Type	-	Y/M/D M/D/Y D/M/Y D.M.Y M.D.Y	M.D.Y
Temperature > Temp	-	C/F	C
Personalize > Add function > Bias	-	Not/Use	Not
Personalize > Add function > SQRT low-cut	-	Not/Use	Use
Personalize > Add function > 1-5V low-cut	-	Not/Use	Not
Personalize > Add function > Alarm delay	-	Not/Use	Not
Personalize > Time print > Alarm	-	HH:MM, HH:MM:SS, M/D H:M, M/D H:M:S, YMD H:M:S	HH:MM
Personalize > Time print > Message	-	HH:MM, HH:MM:SS, M/D H:M, M/D H:M:S, YMD H:M:S, None	HH:MM
Personalize > Time print > RCD On	-	HH:MM, HH:MM:SS, M/D H:M, M/D H:M:S, YMD H:M:S	HH:MM
Personalize > Time print > C.Speed	-	HH:MM, HH:MM:SS, M/D H:M, M/D H:M:S, YMD H:M:S	HH:MM
<b>Setting initialization</b>			
Initialize > Mode	-	Setup+Set/Set	Setup+Set
Initialize > Mode > Are you sure?	-	No/Yes	No
<b>Remote control function (/R1 option)</b>			
Remote > Remote No.	-	1/2/3/4/5	1
Remote > Remote No. > No.	-	Record On Off /Chart speed/Time adjust/ Math start stop/Math reset/Manual print/ Alarm ACK/Message1/Message2/Message3/ Message4/Message5/None	Record On/Off



**Computation function (/M1 option)**

Setup Item	Pen/Dot	Selectable Range or Selections	Default Value
Math > Timer (TLOG) > Timer No.	-	1/2	1
Math > Timer (TLOG) > Mode	-	Off/Relative/Absolute	Absolute
Math > Timer (TLOG) > Interval (Relative)	-	10 min to 24 h (1 min steps)	01:00
Math > Timer (TLOG) > Interval (Absolute)	-	10min/12min/15min/20min/30min/1h/2h/3h/4h/6h/8h/12h/24h	1h
Math > Timer (TLOG) > Ref. Time	-	Hour 0 to 23 (1 hour steps)	00:00
Math > Timer (TLOG) > Reset	-	On/Off	On
Math > Timer (TLOG) > Print	-	On/Off	On
Math > Color > Channel	Dot Model	0A/0B/0C/0D/0E/0F/0G/0J/0K/0M/0N/0P	0A
Math > Color > Color	Dot Model	Purple/Red/Green/Blue/Brown/Black	Purple: 0A/0G Red: 0B/0J Green: 0C/0K Blue: 0D/0M Brown: 0E/0N Black: 0F/0P
Math > Output pen > Pen←CH	Pen Model	Pen: 1 to 4, Channel: 01 to 04/0A to 0J	1pen: 01, 2pen: 02, 3pen: 03, 4pen: 04,
Math > Print2 > CH	-	0A/0B/0C/0D/0E/0F/0G/0J/0K/0M/0N/0P	0A
Math > Print2 > Mode	-	AVE/MIX/SUM/MIN/MAX/INST	AVE
Math > Print2 > SUM scale	-	Off, /s, /min, /h, /day	Off
Math > Bar graph > CH	-	0A/0B/0C/0D/0E/0F/0G/0J/0K/0M/0N/0P	0A
Math > Bar graph > Graph	-	Normal/Center	Normal
Math > Error data > Error	-	+Over/-Over	+Over
Math > Error data > Over	-	Skip/Limit	Skip

**RS-422A/485 communication interface function (/C3 option).**

Setup Item	Pen/Dot	Selectable Range or Selections	Default Value
RS-422/485 > Address	-	1 to 32	1
RS-422/485 > Baud rate	-	1200/2400/4800/9600/19200/38400	9600
RS-422/485 > Data length	-	7/8	8
RS-422/485 > parity	-	Odd/Even/None	Even
RS-422/485 > Protocol	-	NORMAL/MODBUS	NORMAL

**Ethernet communication interface function (/C7 option)**

Setup Item	Pen/Dot	Selectable Range or Selections	Default Value
Ethernet > Host > Host	-	64 characters or less	Blank
Ethernet > Host > Domain	-	64 characters or less	Blank
Ethernet > Local IP > A	-	IP address	0.0.0.0
Ethernet > Local IP > M	-	IP address (Subnet mask)	0.0.0.0
Ethernet > Local IP > G	-	IP address (Default gateway)	0.0.0.0
Ethernet > DNS > DNS	-	On/Off	Off
Ethernet > DNS > P	-	IP address (Primary DNS sever)	0.0.0.0
Ethernet > DNS > S	-	IP address (Secondary DNS sever)	0.0.0.0
Ethernet > DNS > Suffix_P	-	Primary domain suffix	Blank
Ethernet > DNS > Suffix_S	-	Secondary domain suffix	Blank
Ethernet > Login > Login	-	Use/Not	Not
Ethernet > LoginSet > Level	-	Admin/User1 to User6	Admin
Ethernet > LoginSet > Register	-	On/Off	Admin and User1 are On
Ethernet > LoginSet > User	-	16 characters or less	Admin: admin User1 to 6: user1 to user6
Ethernet > LoginSet > Password	-	4 characters or less	Administrator: 0 User1 to 6: 1 to 6
Ethernet > Timeout > Timeout	-	On/Off	Off
Ethernet > Timeout > Duration	-	1 to 120 min	1 min
Ethernet > K. Alive > Keep alive	-	On/Off	On

## Setup Items and Default Values

---

### Adjustment

Setup Item	Pen/Dot	Selectable Range or Selections	Default Value
P_Adj > P_Adj	Dot Model	Hysteresis/Zero/Full	Hysteresis
	Pen Model	Zero/Full	Zero
P_Adj > Pen No.	Pen Model	1/2/3/4	1

### Store

Setup Item	Pen/Dot	Selectable Range or Selections	Default Value
End > End	-	Store/Abort	Store

# Recommended Replacement Periods for Worn Parts

To preserve the reliability of the recorder and to use the recorder in good condition for an extended time, it is recommended that periodic replacements be made on parts. The table below shows the recommended replacement period for expendable parts. The replacement period shown here applies when the recorder is used under standard operating conditions. For the actual replacement period, consider the actual conditions of use.

Replacement of parts other than the chart paper, pen, ribbon cassette, and internal light LED will be carried out by our engineer or an engineer certified by us. Contact your nearest dealer when such replacement is necessary.

## Note

The replacement period of the display and the internal light LED is the half life of the brightness. The deterioration of brightness varies depending on the condition of use, and its determination is subjective. Consider these facts for determining the actual replacement period.

## Pen Model

Item	Replacement Period	Part Name	Note	Quantity Used
Z-fold chart paper	33 days	CHART	When used at 20 mm/h	1
Felt pen	2 km	PEN ASSY	Red Green Blue Violet } At a pen speed of 10 cm/s	1 each
Plotter pen	100,000 characters	PEN ASSY	When printing continuously	1
Display	5 years*	DISPLAY ASSY	For pens 1 to 4	1
Chart paper feed motor	5 years	MOTOR ASSY		1
Plotter carriage	5 years	CARRIAGE ASSY		1
Plotter motor	5 years	MOTOR ASSY	For the X-axis	1
Lever bearing	5 years	BEARING	For the plotter	1
Pen servo	5 years	SERVO ASSY	Shared by all pens (excludes the pen arm ASSY)	1 to 4
Internal light LED	2 years*	LED ASSY		1

\* The half life of the brightness at the factory default brightness setting.

## Dot Model

Item	Replacement Period	Part Name	Note	Quantity Used
Z-fold chart paper	33 days	CHART	When used at 20 mm/h	1
Ribbon cassette	3 months	RIBBON CASSETTE		1
Display	5 years*	DISPLAY ASSY		1
Chart paper feed motor	5 years	MOTOR ASSY		1
Lever	3 years	LEVER ASSY	For the carriage	1
Pulley	3 years	PULLY	For the carriage	2
Carriage motor	5 years	MOTOR ASSY		1
Carriage	5 years	CARRIAGE ASSY		1
Ribbon shift motor	5 years	MOTOR ASSY		1
Ribbon shift gear	5 years	GEAR		1 each
Ribbon feed motor	5 years	MOTOR ASSY		1
Ribbon feed gear	5 years	GEAR		1 each
Internal light LED	2 years*	LED ASSY		1

\* The half life of the brightness at the factory default brightness setting.

