

DIPTAPE™ Indicators – Alloy Versions

- ▶ Temperatures to 300°F (148°C)
- ▶ Pressures to 750 PSI (52 bar)

Rugged brass or stainless steel units are ideal for use in water and oils. Select these units for best temperature and pressure capabilities.

1. Mounting Types

“B” Dimension
(Length Overall):
Indicating Length + A + C

Note: Dimensions “C” and “A”
are dependent on float selected.
See Float Types below.

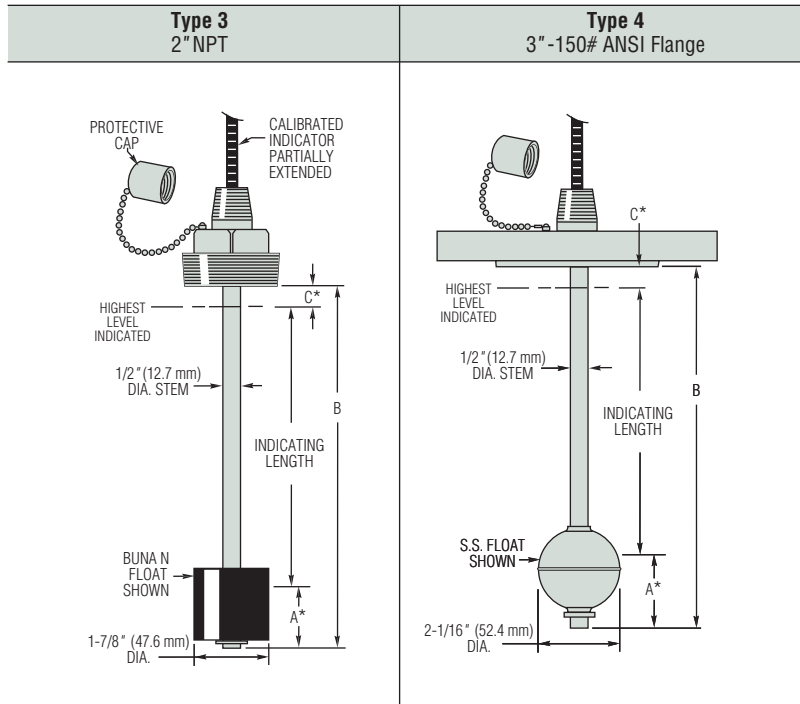

Stem and Mounting Material	Brass or 316 Stainless Steel	316 Stainless Steel Stem with Carbon Steel or 316 Stainless Steel Flange
Indicating Length**	6" to 72" (15.2 cm to 182.9 cm)	
Std. Indication Markings	1/16" or 1 mm increments	

* Dimensions listed below, under "Float Types."
** For longer lengths, please contact factory.

2. Float Types

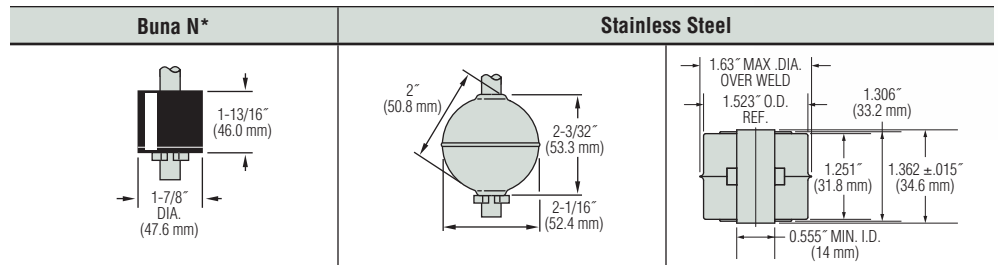

	Buna N*	Stainless Steel	
Float Part Number	73710	73709	138935
Min. Liquid Specific Gravity	0.45	0.67	0.67
Operating Temperatures	Oil: -40°F to +230°F (-40°C to +110°C) Water: to 180°F (+82.2°C)	-40°F to +300°F (-40°C to +148.8°C)	-40°F to +220°F (-40°C to +104°C)
Operating Pressure, Max.	300 psi (21 bar) max. @ 77°F (25°C)	750 psi (52 bar) Mounting Type 3 150 psi (10 bar) Mounting Type 4	150 psi (10 bar)
“A” Dimension (From Mounting Types)	1-1/4" (31.7 mm)	1-3/8" (34.9 mm)	1" (25.4 mm)
“C” Dimension (From Mounting Types)	11/16" (17.5 mm)	3/4" (19.05 mm)	9/16" (14.3 mm)

*Other Wetted Material: Hysol.

