

Define Switching Mode Anytime With Programmable SAFE-PAK® Relays

Provide normally open (N.O.), normally closed (N.C.) or latching output with variable time delays

- ▶ Designed for use with switches or sensors monitoring flow, pressure, level, etc
- ▶ They render non-voltage-producing sensors intrinsically safe for operation in potentially hazardous areas
- ▶ Streamlined housing suited for group-mounting on a common earth-grounded plate for multiple installation
- ▶ UL recognized, FM, CSA and evaluated by MSHA

Operations such as normally open, normally closed or latching are programmed into these versatile SAFE-PAK units by the user during installation. Selection is made by simply connecting sensor wiring (and jumper wire when required) to the proper terminals on the unit as diagrammed on opposite page. All units are programmable, except where otherwise indicated.

See table on Page L-2 for specific approval information.

Options

SAFE-PAK Relays can be supplied with any of the following options on special order. Please consult factory.

- With optically isolated operation
- With zero-crossover load switching
- Longer time delays
- Rail-mounting clip (in addition to standard mounting tabs)

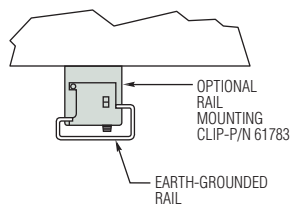

MSHA



Dimensions

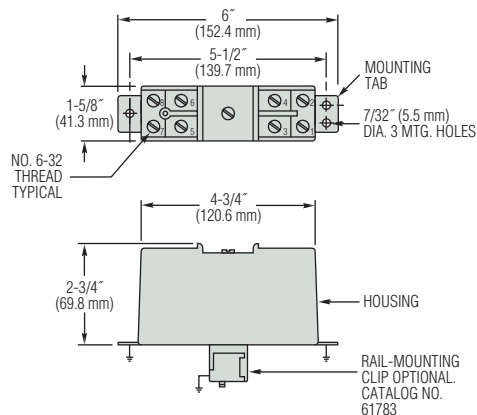

Protective Cover

Assures intrinsic safety integrity of sensor terminals and wiring.

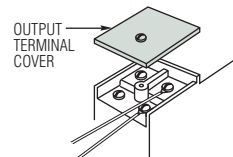

Specifications

Part Number	Operating Voltage ⁴	Load Current Maximum	Load Voltage Range	Turn-On Sensitivity (Typical) ¹	Turn-Off Sensitivity (Typical) ¹	Leakage Current "Off" State, Maximum	Voltage Loss, Maximum	Transient Current ³	Operating Temperature Range
54820 ⚡	95 to 125 VAC, 50-60 Hz	2A	25-250 VAC 50-60 Hz	≤400 K	1 M	3 mA	2 V	20A	+32°F to +140°F (0°C to 60°C)
54825 ⚡		.05A @ 20 V .05A @ 200 V AC or DC	0-250 VAC 50-400 Hz 0-200 VDC	≤30 K	60 K	—	—	—	

Notes:

1. Temperature Dependent.
2. Housing material is blue Lexan®.
3. Repetitive surge currents caused by transient voltage/current pulses may eventually cause permanent damage to triac-type switches if adequate transient suppression is not utilized.
4. All AC voltage and current specifications are RMS values unless otherwise stated.

⚡ – Stock Items.

How To Order

Specify Part Number based on output.

Description – Hybrid Relay	Switching Mode	Part Number
Triac Output, AC Operation	Programmable, N.O., N.C., or latching	54820 ⚡
Reed Switch Output, AC/DC Operation		54825 ⚡
Optional Rail Mounting Clip		61783

⚡ – Stock Items.

Programming the GEMS Programmable SAFE-PAK

Normally Open Load Operation: Switch closure to terminals 5 and 7 turns Programmable Relay “on” and energizes load. Same switch opening will turn “off” Programmable Relay and de-energize load. Terminals 6 and 8 are not used.

Normally Closed Load Operation: Switch closure to terminals 6 and 7 turns Programmable Relay “off” and de-energizes load. Same switch opening will turn “on” Programmable Relay and energize load. Jumper must be connected between terminals 5 and 7...terminal 8 is not used.

Latching “A” Operation: For refill control, momentary switch closure to terminals 5 and 7 turns Programmable Relay “on” and energizes load. Load remains “on” until the Programmable Relay turns “off” with a momentary switch closure at terminals 6 and 7. The load is then de-energized. Jumper must be connected between terminals 7 and 5 and 6.

Note: Latching function should be accomplished on sensor input side of the Programmable SAFE-PAK. No latching function is advised on the output power circuit side.

Latching “B” Operation: Momentary switch closure to terminals 5 and 7 turns Programmable Relay “on” and energizes load. Load remains “on” until the N.C. switch terminals 7 and 8 opens. The Programmable Relay turns “off” and load is de-energized. Terminal 6 and jumper are not used.

Note: Latching function should be accomplished on sensor input side of the Programmable SAFE-PAK. No latching function is advised on the output power circuit side.

Typical Wiring

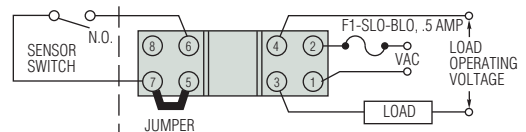
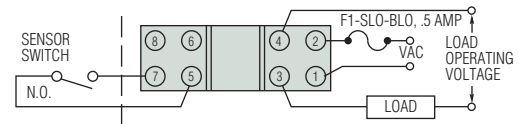

Refill Operation Shown

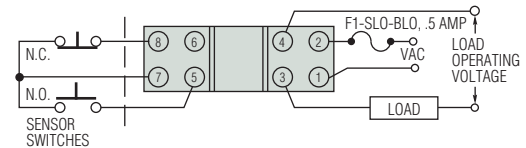
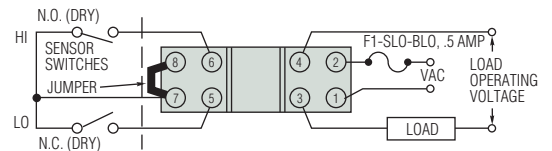

Load Consideration

When these units are used in high-noise electrical systems, connection of a varistor (General Electrical G-MOV or equivalent diode) across terminals 3 and 4 is recommended. Consult factory for recommended varistor protection.

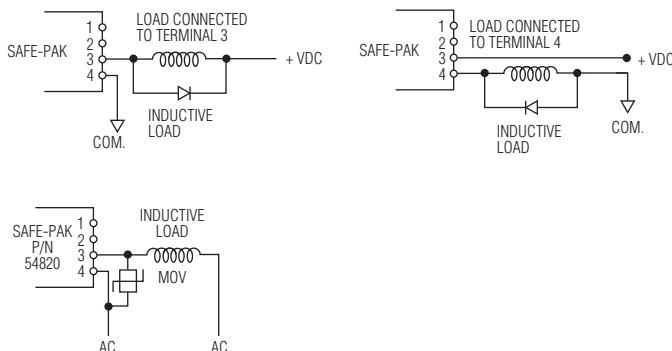

Connecting to Programmable Controllers

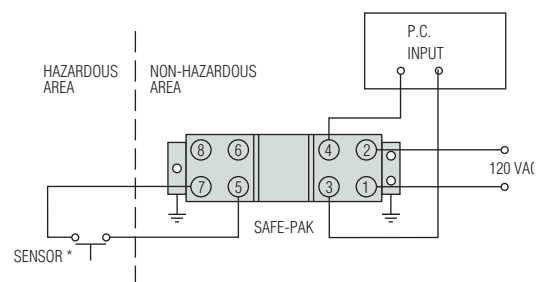

Programmable SAFE-PAK, P/N 54825, providing simple on-off functions for hazardous location, and interfacing with TTL or AC logic input of programmable controller. *Temperature, pressure, position, flow or level.

Installation and maintenance must be in accordance with the National Electrical Code and the applicable GEMS INSTRUCTION, INSTALLATION and SERVICE Bulletin available at www.gemssensors.com